

AXAF Science Center



ACIS Telemetry Products: Level 0 to ASC Archive Interface Control Document

Rev. 1.4 — December 17, 1997

Submitted:	_____	_____
	Joel Kastner ACIS Scientist, ASC Science Data Systems	Date
Concurred:	_____	_____
	David Huenemoerder MIT/ASC Science Manager	Date
Concurred:	_____	_____
	Gregg Germain ASC Data Systems Group Leader, Level 0 Pipelines	Date
Concurred:	_____	_____
	Panagoula Zografou ASC Data Systems Group Leader, ASC Archives	Date
Concurred:	_____	_____
	Janet dePonte ASC Data Systems Group Leader, Level 1 Pipelines	Date
Concurred:	_____	_____
	Fred Seibel Manager, ASC Data Systems	Date
Concurred:	_____	_____
	Martin Elvis Manager, ASC Science Data Systems	Date
Approved:	_____	_____
	Harvey Tananbaum Director, ASC	Date

Document and Change Control Log			
Date	Version	Section	Status
04/30/97	0.3	all	Original release
09/09/97	0.4	all	Preliminary version for MIT/ASC review
09/18/97	1.0	all	First ASC-wide release; lead author: P. Ford
10/09/97	1.1	all	JHK assumes control; RB, WMcL, DPH comments
10/21/97	1.2	4	JMcD, DA comments
11/7/97	1.3	2,4	more JHK, JMcD, DA comments
12/17/97	1.4	4	updates to bias maps & keywords, coords ranges

CONTENTS

1.0	Introduction	1
1.1	Purpose	1
1.2	Scope	1
1.3	Applicable Documents	1
1.4	Functional Description	1
1.4.1	Data Content Summary	1
1.4.2	Source and Transfer Method	2
1.4.3	Recipients and Utilization	2
1.4.4	Pertinent Relationships with Other Interfaces	2
1.5	Assumptions and Constraints	2
1.6	Other Modes and Formats	3
2.0	Environment	4
2.1	Hardware Characteristics and Limitations	4
2.2	Interface Medium and Characteristics	4
2.3	Failure Protection, Detection, and Recovery Features	4
2.3.1	Backup Requirements	4
2.3.2	Security / Integrity Measures	4
2.4	End-Of-File (or Medium) Conventions	4
3.0	Access	5
3.1	Access Tools	5
3.2	Input / Output Protocol	5
3.3	Timing and Sequencing Characteristics	5
4.0	Detailed Interface Specifications	6
4.1	Labeling and Identification	6
4.2	The Origin and Content of Time Fields	7
4.3	Structure and Organization Overview	8
4.4	Substructure Definition and Format	8
4.4.1	Header / Trailer Description Details	8
4.4.2	Parameter Block Files	11
4.4.3	Window Block Files	13
4.4.4	Exposure Record Files	14
4.4.5	Bias Error Files	15
4.4.6	Timed-Exposure Event Files	15
4.4.7	Continuous Clocking Event Files	17
4.4.8	Science Run Report File	18
4.4.9	Analog Housekeeping Files	18
4.4.10	System Configuration Table Files	19
4.5	Bias Map Formats	21
4.6	Volume, Size, and Frequency Estimates	25
Appendix A:	IP&CL Fields and MSID Keywords	A-1
Appendix B:	ACIS Constants	B-1

B.1	CCD Identifiers	B-1
B.2	CCD Row and Column Position Definition	B-1
B.3	Event Grade Code Definition	B-2
B.4	FEP Identifiers	B-3
B.5	Output Register Clocking Modes	B-3
B.6	DEA Query Identifiers	B-3
B.7	Bias Algorithm Selection Codes	B-5
	B.7.1 Timed Exposure Mode	B-5
	B.7.2 Continuous Clocking Mode	B-6
B.8	FEP Science Report Error Codes	B-6
B.9	FEP Science Mode Codes	B-7
	B.9.1 Timed Exposure Mode	B-7
	B.9.2 Continuous Clocking Mode	B-8
B.10	BEP Packing Mode Codes	B-9
	B.10.1 Timed Exposure	B-9
	B.10.2 Continuous Clocking	B-9
B.11	Science Mode Termination Codes	B-9
B.12	Miscellaneous FEP Constants	B-10
B.13	Miscellaneous BEP Constants	B-10

LIST OF TABLES

Table 1:	ACIS Level 0 Timed-Exposure Data Product Files.....	6
Table 2:	ACIS Level 0 Continuous Clocking Data Product Files.....	7
Table 3:	Format of a FITS Keyword Header.....	9
Table 4:	Format of a FITS Binary Table Extension Header.....	10
Table 5:	Timed Exposure Parameter Block File (*_tepbk.fits).....	11
Table 6:	Continuous Clocking Parameter Block File (*_ccpbk.fits).....	12
Table 7:	2-Dimensional Window Block File (*_win2.fits).....	13
Table 8:	1-Dimensional Window Block File (*_win1.fits).....	13
Table 9:	Exposure Records File (*_f_exr.fits).....	14
Table 10:	Bias Error File (*_f_berr.fits).....	15
Table 11:	TE Faint Event Data File (*_f_evtef.fits).....	15
Table 12:	TE Faint-with-bias Event Data File (*_f_evtefb.fits).....	16
Table 13:	TE Graded Event Data File (*_f_evtegf.fits).....	16
Table 14:	TE Very Faint Event Data File (*_f_evtevf.fits).....	17
Table 15:	CC Faint Event Data File (*_f_evccf.fits).....	17
Table 16:	CC Graded Event Data File (*_f_evccgf.fits).....	17
Table 17:	Science Run Report File (*_srr.fits).....	18
Table 18:	DEA Housekeeping File (*_deahk.fits).....	18
Table 19:	System Configuration File (*_sys.fits).....	19
Table 20:	TE Bias Map File (*_f_tebias.fits).....	21
Table 21:	CC Bias Map File (*_f_ccbias.fits).....	23
Table A-1:	Traceability between ACIS IP&CL fields and MSID keywords.....	A-1
Table B-1:	CCD_ID Values.....	B-1
Table B-2:	FEP_ID Values.....	B-3
Table B-3:	ORC_MODE Values.....	B-3
Table B-4:	DEA Controller QUERY_ID Values.....	B-3
Table B-5:	DEA Analog QUERY_ID Values.....	B-5
Table B-6:	BIASALG Values.....	B-5
Table B-7:	Timed Exposure Bias Parameter Usage.....	B-6
Table B-8:	Continuous Clocking Bias Parameter Usage.....	B-6

Table B-9: FEP_ERRS Values.....	B-7
Table B-10: Timed-Exposure FEP_MODE Values.....	B-7
Table B-11: Continuous Clocking FEP_MODE Values.....	B-8
Table B-12: Timed Exposure BEP_MODE Values.....	B-9
Table B-13: Continuous Clocking BEP_MODE Values.....	B-9
Table B-14: TERMCODE Values.....	B-9
Table B-15: Miscellaneous FEP Constants.....	B-10
Table B-16: Miscellaneous BEP Constants.....	B-10

LIST OF UNDETERMINED ITEMS

1.	Whether CC bias row should be replicated into 512 rows of bias file	2
2.	Should maintenance and diagnostic products be described by this ICD?	3
3.	Means by which products are transmitted to the Archive	4
4.	Conversion of VCDU counter values to S/C UTC times	7
5.	Means by which products are transmitted to the Archive	7
6.	Define volume, size, and frequency estimates.	25

1.0 Introduction

This document describes the interface to be employed in transferring telemetry data from the ACIS instrument between the ASC Level 0 processing pipeline and the ASC Data Archive, according to the requirements stipulated in Applicable Document 6.

1.1 Purpose

ACIS Level 0 processing, described in Applicable Document 7, extracts the ACIS science portions of the CTUE telemetry frames. It then decodes (decommutates) the packet streams contained in these portions, according to the ACIS flight software requirements specifications (Applicable Document 1) and, more specifically, according to the ACIS IP&CL definitions (Applicable Document 3).

1.2 Scope

This interface shall apply to all ACIS telemetry data sets that are generated by ASC Level 0 pipelines during the course of the AXAF mission.

1.3 Applicable Documents

	Document	Description
1	MIT 36-01103 Rev. J	ACIS Flight Software Requirements Specification http://acis.mit.edu/sreqj/
2	MIT 36-53226 Rev. A	ACIS Flight Software Detailed Design Specification
3	MIT 36-53204 Rev. K	ACIS Instrument Procedures and Command Language http://acis.mit.edu/ipcl/
4	MIT 36-02205 Rev. C	ACIS DPA to DEA Interface Control Document http://acis.mit.edu/axaf/deadpaicd/
5	MIT 36-02203, Rev. A	ACIS Focal Plane to Detector Housing Interface Control Document
6	ASC AMO-2400 (SE03)	ASC Data System Requirements (ASC.302.93.0008)
7	ASC AMO-2401 (DS01)	ASC Data System Software Design (ASC.500.93.0006)
8	...	Definition of the Flexible Image Transport System (FITS) http://www.gsfc.nasa.gov/astro/fits/documents.html
9	...	ASC Data Products Guide
10	...	HEASARC proposal for time/date formats in FITS headers ftp://nssdc.gsfc.nasa.gov/pub/fits/year2000_proposal.txt

1.4 Functional Description

1.4.1 Data Content Summary

All ACIS data sets generated by the Level 0 processing pipeline shall consist of digital data files conforming to the FITS format (Applicable Document 8). These files contain header keyword entries and binary table (BINTABLE) extensions (except for bias files, which do not contain BINTABLE extensions). Each entry in these files, apart from generic ASC header keywords, corresponds to an element in the ACIS science telemetry stream. The names of these keywords and

table items are contained in a series of templates, listed in Appendix A, which serve as cross-references between ACIS packet contents and Level 0 data products. Appendix B lists some useful telemetry flag field values.

1.4.2 Source and Transfer Method

ACIS Level 0 products shall be created by the ACIS Data Extractor described in §4.5.3.4.2 of Applicable Document 7.

1.4.3 Recipients and Utilization

It is anticipated that the primary recipients of the data products described in this document will be the ASC Data Archive, and that the archived Level 0 data products subsequently will be accessed and utilized primarily by the ASC Level 1 ACIS data processing pipeline. Certain Level 0 products, in particular Bias Map files, also may be routinely distributed directly to the PI of the AXAF observation. It is also anticipated that, in certain cases, PIs of AXAF observing programs may request, and will be granted, direct access to any or all of the other Level 0 products. Identification of additional recipients of Level 0 products, and the uses to which they may wish to put them, falls beyond the scope of this document.

1.4.4 Pertinent Relationships with Other Interfaces

Changes to the definition of ACIS science telemetry packets and their data fields, as specified in Applicable Document 3, may affect the Level 0 data products described in the current document.

1.5 Assumptions and Constraints

For each ACIS science event run reported in the AXAF telemetry stream, Level 0 processing shall generate a set of product files as shown in Table 1 (timed exposure; TE) or Table 2 (continuous clocking; CC). Since all runs use either Timed-Exposure or Continuous-Clocking mode, either a CC or a TE parameter block file shall always be generated. If the parameter block specified window selection filters, the appropriate window file shall be generated.

Each ACIS Front End Processor (FEP) that generates telemetry will be represented by a pair of data files—an exposure file that summarizes the exposure epoch and number of candidate events within each CCD frame, and an event file that contains the events themselves. Both files are sorted into time order, as implied by §5.3 and §5.4 of Applicable Document 6. Pixel addresses are expressed in CCD coordinates in which the row and column indices span the range 0–1023, where the (0,0) origin is the pixel nearest to output node A of the CCD. These coordinates are referred to in the present document as CCDX, CCDY so as to avoid confusion with the 1-1024 based CHIPX, CHIPY coordinate system used in Level 1 processing.

CCD bias pixel packets will be assembled into bias image files in FITS format. If, however, the bias maps were never received, they will be omitted from the Level 0 product. Timed-exposure bias maps shall contain 1024x1024 pixels. Continuous clocking bias maps shall contain 1024x512 pixels, where all 512 rows of the CC bias map replicate the same CC bias row(TBD).

Any bias pixel error packets encountered during Level 0 processing shall be assembled into Bad Bias Pixel files, one for each FEP that reports bias errors.

1.6 Other Modes and Formats

The following categories of ACIS telemetry are used for maintenance and diagnostic purposes, and are not **currently** included within the interface defined by this document:

- All data derived from Timed-Exposure and Continuous-clocking Raw Pixel modes
- All data derived from Timed-Exposure Histogram mode
- Start-up messages
- Fatal error messages
- All Memory Dumps (except the System Configuration Table)
- Back-End Processor Software Housekeeping
- Command Verification

2.0 Environment

2.1 Hardware Characteristics and Limitations

All binary integers within ACIS Level 0 products are written in “big-endian” format, i.e. with their more significant bytes preceding their less significant bytes (this is the byte order used by Sun, SGI, and Apple machines, in contrast with the “little-endian” format used by Dec and Intel processors). Within FITS keyword headers, unsigned integer values are represented as positive decimal quantities. Within FITS binary table extensions, unsigned n -byte integers whose most significant bit can be ON¹ shall be described by TFORM values of nB .

These products contain double-precision binary floating point fields. They are written in IEEE-754 format, using the “big-endian” convention, *i.e.* the sign bit and the high-order 7 bits of the exponent are in the first byte, the 4 low-order bits of the exponent and the 4 high-order bits of the mantissa and in the second byte, and so on. Special values, *e.g.* NaN, shall not occur.

2.2 Interface Medium and Characteristics

Level 0 products shall be created on a UNIX file system. While they are being written, their FITS headers may contain invalid keyword values (*e.g.* NAXIS2, the number of binary table rows), and the bias image files may be sparse. Care must be taken not to read or copy these files until they are complete.

2.3 Failure Protection, Detection, and Recovery Features

2.3.1 Backup Requirements

Once created, ACIS Level 0 products are transmitted to the ASC Archive by TBD means. All further responsibility for the products rests with the Archive.

2.3.2 Security / Integrity Measures

The keyword headers of all Level 0 products shall contain an indication of their total byte length so that a file truncation can be detected. For bias image files, this is $|L_{HDR}|_{2880} + |2*x*y|_{2880}$, where L_{HDR} is the length of the keyword header (in bytes), x is the value of the NAXIS1 header keyword, y is the value of the NAXIS2 header keyword, and $|n|_{2880}$ denotes the smallest multiple of 2880 that is greater than, or equal to, n . The equivalent expression for the length of a Level 0 binary table file is $|L_{HDR}|_{2880} + |L_{THDR}|_{2880} + |2*x*y|_{2880}$, where L_{THDR} is the byte length of the binary table header, and x and y are the values of NAXIS1 and NAXIS2 within that header.

2.4 End-Of-File (or Medium) Conventions

All Level 0 products obey the FITS conventions of Applicable Document 8—headers are terminated by “END” keywords; the size of image arrays and binary tables is defined by the NAXIS1 and NAXIS2 header keywords.

1. *i.e.* $T_{\max} > 2^{8*n-1} - 1$, where T_{\max} is the TLMAX value of the n -byte data field.

3.0 Access

3.1 Access Tools

Since ACIS Level 0 products obey the formatting rules described in Applicable Document 8, they may be accessed by any software that conforms to those standards, including all versions of the FITSIO libraries that support the BINTABLE extension.

3.2 Input / Output Protocol

All Level 0 products can be accessed by FITSIO library routines (see Applicable Document 8) that support the BINTABLE extension. Given the method by which some unsigned integer fields are represented (see Section 2.1, above), care must be taken in converting these fields to numeric values.

3.3 Timing and Sequencing Characteristics

The natural subdivision (“atomic unit”) of ACIS telemetry is the Science Run, which signals its start by writing a *dumpedTeBlock* or *dumpedCcBlock* packet to the science telemetry stream, and which continues until the next such packet. By contrast, the natural subdivision of AXAF data is the Observation Request (OR), which may span several ACIS science runs. ACIS telemetry will therefore be processed in batches, each spanning the period of a single observation request, and the data products will be further sub-divided into individual science runs.

4.0 Detailed Interface Specifications

4.1 Labeling and Identification

The data files generated by the Level 0 processing pipeline shall be assigned external names as shown in Table 1 (for ACIS Timed-Exposure mode) and Table 2 (for Continuous Clocking mode). The names obey the following convention:

```
acis0Vnn_nns000000000_f_product.fits
```

where 'acis0' denotes an ACIS Level 0 file, 'Vnn_nn' is the version of the AXAF IP&CL used to decode the telemetry packets (e.g. V05_02 for IP&CL version 5.02), 's' denotes the origin of the data (possible values: x = XRCF, f = flight, t = TRW, b = Ball, s = simulation), '000000000' is a 9-digit time stamp indicating the time of the start of the Science Run in seconds since Dec. 31 1993 (equivalent to the value of runStartTime in the ACIS IP&CL [Applicable Document 3] and RUNSTART in certain extension headers; see Sec. 4.2), and the (optional) 'f_' denotes the index of a particular ACIS front end processor (FEP). Note that the System Configuration files violate this convention in that their 'f' field counts the number of times that this table appears in the telemetry.

Table 1: ACIS Level 0 Timed-Exposure Data Product Files

Title	File Name	Contents
TE Parameter File	*_tepbk.fits	Timed exposure (TE) science run parameters
2-D Window File	*_win2.fits	Optional TE (2-dimensional) window filter parameters
Science Report File	*_srr.fits	Science run report (common to TE and CC modes)
DEA Housekeeping	*_deahk.fits	DEA housekeeping report
System Configuration	*_sys.fits	The <i>m</i> 'th readout of the system configuration table
Exposure File	*_f_exr.fits	Per-exposure statistics, one per FEP
Bias Error File	*_f_berr.fits	Optional bias pixel parity errors, one per FEP
Pixel Event File (various formats depending on instrument mode)	*_f_evtef.fits	TE faint (3x3) event file
	*_f_evtefb.fits	TE faint-with-bias (3x3) event file
	*_f_evtegf.fits	TE graded event file
	*_f_evtevf.fits	TE very faint (5x5) event file
Bias File	*_f_tebias.fits	TE CCD bias array file, one per FEP

Table 2: ACIS Level 0 Continuous Clocking Data Product Files

Title	File Name	Contents
CC Parameter File	*_ccpbk.fits	Continuous clocking (CC) science run parameters
1-D Window File	*_win1.fits	Optional CC (1-dimensional) window filter parameters
Science Report File	*_srr.fits	Science run report (common to TE and CC modes)
DEA Housekeeping	*_deahk.fits	DEA housekeeping report
System Configuration	*_sys.fits	The m 'th readout of the system configuration table
Exposure File	*_f_exr.fits	Per-exposure statistics, one per FEP
Bias Error File	*_f_berr.fits	Optional bias pixel parity errors, one per FEP
Pixel Event File	*_f_evccf.fits	CC faint (1x3) event file
	*_f_evccg.fits	CC graded event file
Bias File	*_f_ccbias.fits	CC CCD bias array file, one per FEP

4.2 The Origin and Content of Time Fields

All CCD exposures (frames) obtained by ACIS are tagged with the value of the (nominally) 100 kHz BEP counter, whose value is reported once per telemetry science frame (2.05 second). The BEP clock values may thereby be related to the more accurate spacecraft clock via the VCDU counters in the telemetry minor frame headers. During Level 0 processing, the VCDU counters are themselves related to observatory UTC, *i.e.* earth receipt UTC minus one-way light time, via a method **TBD**.

In the header of each data file is recorded the S/C UTC corresponding to the BEP counter values for the first and last CCD exposures processed¹ during the science run, in keywords TSTART and TSTOP, respectively (the values of DATE-OBS and TIME-OBS correspond to TSTART). The corresponding BEP clock values are recorded as STARTBEP and STOPBEP, respectively. The start of the science run itself (*i.e.* runStartTime in the ACIS IP&CL; Applicable Document 3) is recorded in certain extension headers as RUNSTART.

The indices of the telemetry science frames which encompass the ACIS science run data in question are contained in STARTMJF, STARTMNF (corresponding to TSTART) and STOPMJF, STOPMNF (corresponding to TSTOP). That is, the initial data for the science run in question are found in telemetry major frame STARTMJF, minor frame STARTMNF, while the last science run data are found in major frame STOPMJF, minor frame STOPMNF. The presence of these keywords, plus temporal information stored in the ASC Data Archive, allows one to recover the position of the science run in question from ACIS telemetry, if necessary (TBD).

Two time values are recorded for each frame in the exposure record files (see Section 4.4.4). These values are BEPTICKS, the BEP clock value at the start of the exposure, and TIME, the mid-exposure S/C UTC. TIME is calculated according to the following, for timed exposure (TE) and continuous clocking (CC) modes:

$$\begin{aligned} \text{TE:} & & = \text{TSTART} + \text{SCETDIFF} + 0.05 * \text{EXPTIME} \\ \text{CC:} & & = \text{TSTART} + \text{SCETDIFF} + (\text{TROW} + .5) * \text{EXPTIME} * 10^{-6} \end{aligned}$$

1. Typically, 2 exposures are skipped (not processed) at the start of a Science Run; TSTART corresponds to the time of the first exposure *processed*.

where `SCETDIFF` is the number of seconds (TAI) elapsed since `TSTART` and is derived from the BEP counter value for the exposure in question (note that the units of `EXPTIME` are 0.1 s for TE mode and microseconds for CC mode). The value of `TIME` corresponding to a given exposure is also placed in each event record (see Section 4.4.6 and Section 4.4.7).

Some less time-critical ACIS telemetry packets contain an alternative time field, `BEPCOUNT`. This represents the number of BEP timer interrupts since the last processor reset. Although the nominal interrupt time is 100 milliseconds, this may vary with processor load. In practice, the accompanying `SCETDIFF` values are reliable to 2.05 seconds.

The format of times & dates contained in the primary FITS headers of Level 0 data products (Table 3) shall conform to the proposal described in Applicable Document 10.

4.3 Structure and Organization Overview

The “science run” forms a natural unit by which ACIS telemetry can, and should, be divided. The Level 0 processing system shall therefore segregate its products by run number. Since the ACIS instrument interleaves event telemetry from its CCDs in an unpredictable manner, the events from each CCD shall be written to a separate Level 0 file. The task of merging the events from individual CCDs into a single product is left for the Level 1 ACIS pipeline.

4.4 Substructure Definition and Format

4.4.1 Header / Trailer Description Details

All ACIS Level 0 products shall consist of files in FITS format, as defined in Applicable Document 8. Each FITS file is comprised of a primary component and optional extension components. Each of these components is divided into two parts: a header section and an (optional) data section. The length of each section is a multiple of 2880 bytes. The header section is further subdivided into 80-byte “records” containing only ASCII characters. With the exception of bias files, which are described in Section 4.5 below, all ACIS Level 0 files contain Binary Table extensions.

Table 3 shows the keywords that will be present in the headers of all ACIS Level 0 products, whether they describe binary tables or images. Each 80 byte line is left justified and blank filled on the right. Following the ‘END’ keyword, ASCII blanks are appended until the header length is a multiple of 2880 bytes (36 lines).

The binary tables are further described by an extension header that immediately follows the keyword header of Table 3. The format of a “generic” FITS binary table file is shown in Table 4—the header, composed of lines of 80-byte ASCII characters, begins with a group of “required” keywords (`XTENSION` through `GCOUNT`), continues with zero or more product-specific keywords, and ends with `TFIELDS` and groups of keywords (`TFORM m` through `TLMAX m`) that define each column of the binary table that follows the FITS header. After the terminating ‘END’ keyword, blank bytes are added until the length of the extension header is a multiple of 2880 bytes. In the following tables, each Level 0 product is defined in terms of its product-specific keywords and its binary table fields. Each is ultimately derived from ACIS science telemetry fields, defined in Applicable Document 3, and related to Measurement Stimulus Identifier (MSID) field names in Appendix A, Table 1.

The table itself immediately follows the extension header. Its length is determined by the values of the `NAXIS1` and `NAXIS2` keywords in the extension header (not those in the initial keyword

Table 3: Format of a FITS Keyword Header

SIMPLE =	T	/	FITS STANDARD
BITPIX =	8	/	Binary Data
NAXIS =	0	/	No image data array present
EXTEND =	T	/	There may be standard extensions
COMMENT			
COMMENT	AXAF	FITS Event File:	ACIS Level 0
COMMENT			
MISSION =	'AXAF'	/	Advanced X-ray Astrophysics Facility
TELESCOP=	'AXAF'	/	Telescope used
INSTRUME=	'ACIS'	/	AXAF CCD Imaging Spectrometer
OBS_ID =	'RX-EE-1.001A'	/	Observation ID from OFLS
DATE-OBS=	'25/02/97'	/	Date of observation start
TIME-OBS=	'20:00:00'	/	Time of observation start
DATE-END=	'25/02/97'	/	Date of observation end
TIME-END=	'20:34:06'	/	Time of observation end
MJD-OBS =	58904.84293	/	MJD of observation start
BIAS_DAT=	'26/02/96'	/	Obs date of Bias frame
BIAS_TIM=	'15:14:09'	/	Obs time of Bias frame
CREATOR =	'psci 2.3'	/	Program creating this file
ASCVER =	'ACIS_L0_2.0'	/	Format spec for this file
ORIGIN =	'ASC'	/	Organization creating file
DATE =	'26/02/96'	/	Date file was created
REVISION=	0	/	Processing revision
EVENT =	'EVENTS'	/	PROS: Name of extension with events
DATACLAS=	'OBSERVED'	/	Data is observed, not simulated
MJDREFI =	50814	/	MJD of clock start
MJDREFF =	0.000731296	/	63.184/86400
TSTART =	825365629.0	/	Observation start time, seconds
TSTOP =	825366847.0	/	Observation stop time, seconds
TELAPSE =	1218.0	/	Elapsed time, seconds
TIMEUNIT=	's'	/	HEASARC: time unit
TIMESYS =	'1998.0'	/	HEASARC: time system
TIMEDEL =	0.200000003	/	Smallest meaningful time increment, s
TIMEREFS=	'LOCAL'	/	Time is local for data
TIMVERSN=	'OGIP/93-003a'	/	OGIP time convention
TASSIGN =	'SATELLITE'	/	Source of time assignment
COMMENT			
COMMENT	AXAF	FITS Event File:	Special ACIS Keywords
COMMENT			
READMODE=	'TIMED'	/	CCD exposure mode
DATAMODE=	'FAINT'	/	CCD event telemetry mode
RUN_ID =	1	/	Science run index
STARTBEP=	0	/	BEP timer value at TSTART
STOPBEP=	0	/	BEP timer value at TSTOP
STARTMJF=	0	/	Maj frame containing start of Sci Run
STARTMNF=	0	/	Min frame containing start of Sci Run
STOPMJF =	0	/	Maj frame containing end of Sci Run
STOPMNF =	0	/	Min frame containing end of Sci Run
COMMENT			
COMMENT	Product-specific	keywords are	inserted here
END			

Table 4: Format of a FITS Binary Table Extension Header

XTENSION=	'BINTABLE'	/ This is a binary table
BITPIX	=	8 / Bits per 'pixel'
NAXIS	=	2 / Number of 'axes'
NAXIS1	=	<i>size</i> / Width of a table row in bytes
NAXIS2	=	<i>rows</i> / Number of rows of binary data
PCOUNT	=	0 / Random parameter count (required but ignored)
GCOUNT	=	1 / Number of data groups
TFIELDS	=	<i>m</i> / Number of data fields per row
EXTNAME	= 'EVENTS '	/ Table name
COMMENT		
COMMENT	Groups of keywords	to describe each column of the binary extension
COMMENT		
TFORM1	=	<i>nC</i> / Dimension and data type of first field
TTYPE1	= 'name1 '	/ Label of first field
TUNIT1	= 'units1 '	/ Data units of first field (optional)
TLMIN1	=	<i>minval1</i> / Minimum field value (optional)
TLMAX1	=	<i>maxval1</i> / Maximum field value (optional)
TFORM2	=	<i>nC</i> / Dimension and data type of second field.
TTYPE2	= 'name2 '	/ Label of second field
TUNIT2	= 'units2 '	/ Data units of second field (optional)
TLMIN2	=	<i>minval2</i> / Minimum field value (optional)
TLMAX2	=	<i>maxval2</i> / Maximum field value (optional)
.		
.		
TFORM <i>m</i>	=	<i>nC</i> / Dimension and data type of <i>m</i> 'th field.
TTYPE <i>m</i>	= 'name <i>m</i> '	/ Label of <i>m</i> 'th field
TUNIT <i>m</i>	= 'units <i>m</i> '	/ Data units of <i>m</i> 'th field (optional)
TLMIN <i>m</i>	=	<i>minvalm</i> / Minimum field value (optional)
TLMAX <i>m</i>	=	<i>maxvalm</i> / Maximum field value (optional)
END		
followed by padding sufficient to make the binary table header a multiple of 36 lines (2880 bytes)		
FITS binary table contents		
<i>(size x rows)</i> bytes of binary data		
followed by padding sufficient to make the length of the binary table a multiple of 2880 bytes		

header of Table 3), and blank bytes are added until it, too, is a multiple of 2880 bytes in length.

4.4.2 Parameter Block Files**Table 5: Timed Exposure Parameter Block File (*_tepbk.fits)**

Additional FITS Keyword Header Items					
PBLOCK	=	'0x80000001'	/	Parameter Block Identifier	
WIND_ID	=	'0xa0000001'	/	Window block Identifier	
FEP_MODE=		2	/	0:Raw; 1:Histogram; 2:3x3; 3:15 TBD	
BEP_MODE=		1	/	0:Faint; 1:Faint Bias; 2:Graded; 3:15 TBD	
SUM_2X2 =		0	/	On-chip summing. 0:None; 1:Sum 2x2	
NOBADPIX=		1	/	Disable bad pixel map. 0:Use map; 1:Ignore map	
NOBADCOL=		1	/	Disable bad column map. 0:Use map; 1:Ignore mp	
BIAS_CAL=		1	/	Enable bias calibration. 0:Don't compute; 1:Comp	
SENDBIAS=		0	/	Telemeter bias data. 0:Don't send; 1: Send	
STARTROW=		0	/	Index of first row to clock out CCDs	
ROWCNT =		1023	/	One less than the number of rows to clock out	
OCLKPAIR=		8	/	Number of pairs of overclock pixels per output	
ORC_MODE=		0	/	Output register clocking mode	
EXPTIMEA=		35	/	Primary exposure time in units of 1/10s	
EXPTIMEB=		0	/	Secondary exposure time in units of 1/10s	
DTYCYCLE=		0	/	Number of Secondary exposures per Primary	
PHAMIN =		0	/	Minimum acceptable pulse height	
PHARANGE=		-1	/	Range of accepted pulse heights	
GRADEMA1=		'FFFFFFFF'	/	Hex bit pattern of accepted grade flags	
GRADEMA2=		'FFFFFFFF'	/	Hex bit pattern of accepted grade flags	
GRADEMA3=		'FFFFFFFF'	/	Hex bit pattern of accepted grade flags	
GRADEMA4=		'FFFFFFFF'	/	Hex bit pattern of accepted grade flags	
GRADEMA5=		'FFFFFFFF'	/	Hex bit pattern of accepted grade flags	
GRADEMA6=		'FFFFFFFF'	/	Hex bit pattern of accepted grade flags	
GRADEMA7=		'FFFFFFFF'	/	Hex bit pattern of accepted grade flags	
GRADEMA8=		'FFFFFFFF'	/	Hex bit pattern of accepted grade flags	
HISTOCNT=		1	/	Number of exposures per histogram	
RCMPSLOT=		0	/	Slot identifier of raw-mode compression table	
EXP_SKIP=		30	/	Number of exposure frames to skip at run start	
DEALOAD =		0	/	If not zero, pointer to DEA Load in RAM	
FEPLOAD =		0	/	If not zero, pointer to FEP Load in RAM	
FITS binary table contents (one entry per active FEP)					
Field	TTYPE	TUNIT	TFORM	TLMAX ^a	Comment
1	CCD_ID	n/a	1I	9	CCD ID
2	FEP_ID	n/a	1I	5	Front End Processor ID
3	VIDRESP	n/a	1I	1	CCD video chain response selection, 0 for 1:1
4	EVT_THR	ADU	4I	4095	Event thresholds for nodes A-D (TLMIN=-4096)
5	SPL_THR	ADU	4I	4095	Split thresholds for output nodes A-D
6	BCMPSLOT	n/a	1I	255	Slot identifier for bias map compression tab
7	BIASALG	n/a	1I	255	Bias algorithm id. 1:whole frame; 2:strip
8	BIASARG0	n/a	1I	32767	Bias argument 0 (TLMIN=-32768)
9	BIASARG1	n/a	1I	32767	Bias argument 1 (TLMIN=-32768)
10	BIASARG2	n/a	1I	32767	Bias argument 2 (TLMIN=-32768)

FITS binary table contents (one entry per active FEP) (Continued)					
Field	TTYPE	TUNIT	TFORM	TLMAX ^a	Comment
11	BIASARG3	n/a	1I	32767	Bias argument 3 (TLMIN=-32768)
12	BIASARG4	n/a	1I	32767	Bias argument 4 (TLMIN=-32768)
13	VID_OFF	n/a	4I	4095	Video offsets for CCD output nodes A-D

a. TLMIN is zero, except where noted.

The instrument configuration for each science run will be described by a Parameter Block File, either for Timed Exposure Mode (Table 5) or Continuous Clocking Mode (Table 6). Most of the mode parameters are defined in the keyword section. The binary table contains a row for each FEP that was active during the science run. Note that it is possible, but not usual, for more than one FEP to process data from the *same* CCD.

Table 6: Continuous Clocking Parameter Block File (*_ccpbk.fits)

Additional FITS Keyword Header Items					
PBLOCK	= '0x80000001'				/ Parameter Block Identifier
WIND_ID	= '0xa0000001'				/ Window block Identifier
FEP_MODE=		2	/	0:Raw; 1:Histogram; 2:1x3; 3:15	TBD
BEP_MODE=		1	/	0:Faint; 1:Graded; 2:15	TBD
NOBADCOL=		1	/	0:Use bad CC column map; 1:Ignore bad column map	
BIAS_CAL=		1	/	0:Don't recompute bias maps; 1:Recompute maps	
SENDBIAS=		0	/	0:Don't Telemeter bias maps; 1: Telemeter them	
SUMROW =		0	/	Number of CCD rows to sum (powers of 2)	
SUMCOL =		0	/	Number of CCD columns to sum (powers of 2)	
OCLKPAIR=		8	/	Number of pairs of overclock pixels per output	
ORC_MODE=		0	/	Output register clocking mode	
PHAMIN =		0	/	Minimum acceptable pulse height	
PHARANGE=		-1	/	Range of accepted pulse heights	
GRADEMAP=	'FFFF'		/	Hex bit pattern of accepted grade flags	
RCMPSLOT=		0	/	Slot identifier of raw-mode compression table	
EXP_SKIP=		30	/	Number of exposure frames to skip at run start	
DEALOAD =		0	/	If not zero, pointer to DEA Load in RAM	
FEPLOAD =		0	/	If not zero, pointer to FEP Load in RAM	
FITS binary table contents (one entry per active FEP)					
Field	TTYPE	TUNIT	TFORM	TLMAX ^a	Comment
1	CCD_ID	n/a	1I	9	CCD ID
2	FEP_ID	n/a	1I	5	Front End Processor ID
3	VIDRESP	n/a	1I	1	CCD video chain response selection, 0 for 1:1
4	EVT_THR	ADU	4I	4095	Event thresholds for nodes A-D (TLMIN=-4096)
5	SPL_THR	ADU	4I	4095	Split thresholds for output nodes A-D
6	BIASALG	n/a	1I	255	Bias algorithm id. 1:whole frame; 2:strip
7	BIASREJ	n/a	2B	65535	Bias algorithm parameter
8	VID_OFF	n/a	4I	4095	Video offsets for CCD output nodes A-D

- a. TLMIN is zero, except where noted.

4.4.3 Window Block Files

The instrument configuration may be further qualified by a set of window filters. Each row of the binary table describes a single window, up to the maximum number of 36. In Timed-Exposure Mode, the windows are two-dimensional (Table 7). In Continuous Clocking Mode, they are one-dimensional (Table 8).

Table 7: 2-Dimensional Window Block File (*_win2.fits)

Additional FITS Keyword Header Items					
WIND_ID = '0xe0000001' / 2-Dimensional Window Block Identifier					
FITS binary table contents (one entry per window)					
#	TTYPE	TUNIT	TFORM	TLMAX	Comment
1	CCD_ID	n/a	1I	9	CCD ID
2	LL_CCDX	n/a	1I	1023	Chip lower left corner x value (CCD column)
3	LL_CCDY	n/a	1I	1023	Chip lower left corner y value (CCD row)
4	CCDCOL	n/a	1I	1023	Number of CCD columns (minus 1) covered by window
5	CCDROW	n/a	1I	1023	Number of CCD rows (minus 1) covered by window
6	SAMP_CYC	n/a	1I	255	Event sampling: 0=reject all, 1= accept all, 2=accept every other, 3=accept every 3rd...
7	PHAMIN	ADU	1I	4095	Minimum event amplitude accepted by window
8	PHARANGE	ADU	2B	65535	Range of event amplitudes accepted by window

Table 8: 1-Dimensional Window Block File (*_win1.fits)

Additional FITS Keyword Header Items					
WIND_ID = '0xe0000001' / 2-Dimensional Window Block Identifier					
FITS binary table contents (one entry per window)					
#	TTYPE	TUNIT	TFORM	TLMAX	Comment
1	CCD_ID	n/a	1I	9	CCD ID
2	LL_CCDX	n/a	1I	1023	Chip lower left corner x value (CCD column)
3	CCDCOL	n/a	1I	1023	Number of CCD columns (minus 1) covered by window
4	SAMP_CYC	n/a	1I	255	Event sampling: 0=reject all, 1= accept all, 2=accept every other, 3=accept every 3rd...
5	PHAMIN	ADU	1I	4095	Minimum event amplitude accepted by window
6	PHARANGE	ADU	1I	24570	Range of event amplitudes accepted by window

4.4.4 Exposure Record Files

An Exposure Records file (Table 9) is created for each FEP that generates exposure packets. This file contains a binary table with one row for each exposure. Since the FEP will skip exposures when it is incapable of processing the incoming events fast enough, the exposure counters (EXPNO) will be in ascending order, but some exposures may be missing.

Table 9: Exposure Records File (*_f_exr.fits)

Additional FITS Keyword Header Items					
RUNSTART=	3924313546	/	Science Run Start in units of BEP clock		
PBLOCK	= '0x80000001'	/	Parameter Block Identifier		
WIND_ID	= '0xa0000001'	/	Window block Identifier		
BIASTART=	3895671628	/	Bias Run Start in units of BEP ticks		
BIAS_ID	= '0x80000002'	/	PBLOCK for last bias calibration		
FEP_ID	=	2	/ Front End Processor ID: 0-5		
CCD_ID	=	1	/ CCD id: 0 - 9		
FITS binary table contents (one entry per CCD exposure)					
#	TTYPE	TUNIT	TFORM	TLMAX ^a	Comment
1	TIME	s	1D	n/a	S/C UTC corresponding to mid-exposure
2	EXPTIME	var ^b	1I	32767	Duration of exposure (TE), or row readout time (CC)
3	BEPTICKS	n/a	1J	2 ³²	BEP Time-tag at start of exposure
4	EXPNO	n/a	1J	2 ³¹ -1	exposure number since start of science run
5	EVTSENT	n/a	1J	2 ³¹ -1	number of events sent in data records
6	THR_PIX	n/a	1J	2 ²⁰	pixels above respective threshold level
7	DROP_AMP	n/a	1J	2 ³¹ -1	# discarded events due to corrected amplitude
8	DROP_POS	n/a	1J	2 ³¹ -1	# discarded events due to CCD position
9	DROP_GRD	n/a	1J	2 ³¹ -1	# discarded events due to grade code
10	BERR_SUM	n/a	1J	2 ³¹ -1	# pixel bias errors so far in science run
11	DELTOCLK	ADU	4I	4095	output node delta overclock values (TLMIN=-4096)

- a. TLMIN is zero, except where noted.
- b. 0.1 seconds for timed exposure mode; microseconds for continuous clocking.

4.4.5 Bias Error Files

When a FEP detects a parity error in its bias memory (most likely the result of a charged particle event), it writes a `biasError` telemetry packet. These are written to Bias Error files (Table 10), one for each FEP that reported at least one such error during that particular science run.

Table 10: Bias Error File (*_f_berr.fits)

Additional FITS Keyword Header Items					
RUNSTART=	3924313546 / Science Run Start in units of BEP clock				
FEP_ID =	2 / Front End Processor ID: 0-5				
CCD_ID =	1 / CCD id: 0 - 9				
FITS binary table contents (one entry per bias error)					
#	TTYPE	TUNIT	TFORM	TLMAX	Comment
1	TIME	s	1D	n/a	S/C UTC corresponding to mid-exposure
2	EXPNO	n/a	1J	$2^{31}-1$	Exposure number since start of science run
3	CCDX	n/a	1I	1023	CCD column position of bad pixel within bias map
4	CCDY	n/a	1I	1023	CCD row position of bad pixel within bias map
5	BIAS	ADU	1I	4095	Bias map pixel value which produced the error and which will be replaced by 4094 in the bias map

4.4.6 Timed-Exposure Event Files

In one of the timed-exposure modes, all X-ray events from a given FEP are written to one of the event files described in Table 11 through Table 14. The EXPNO field serves as an index into the accompanying exposure record file.

Table 11: TE Faint Event Data File (*_f_evtef.fits)

Additional FITS Keyword Header Items					
FEP_ID =	2 / Front End Processor ID: 0-5				
CCD_ID =	1 / CCD id: 0 - 9				
FITS binary table contents (one entry per event)					
#	TTYPE	TUNIT	TFORM	TLMAX	Comment
1	TIME	s	1D	n/a	S/C UTC corresponding to mid-exposure
2	EXPNO	n/a	1J	$2^{31}-1$	Exposure number since start of science run
3	CCDX	n/a	1I	1022	CCD column position of center pixel of event (TLMIN=1)
4	CCDY	n/a	1I	1022	CCD row position of center pixel of event (TLMIN=1)
5	RAW_PHAS	ADU	9I	4095	3x3 array of raw pixel pulse heights

Table 12: TE Faint-with-bias Event Data File (*_f_evtefb.fits)

Additional FITS Keyword Header Items					
FEP_ID =	2	/	Front End Processor ID:	0-5	
CCD_ID =	1	/	CCD id:	0 - 9	
INITOCLA=	123	/	Average initial overclock for node A (ADUs)		
INITOCLB=	123	/	Average initial overclock for node B (ADUs)		
INITOCLC=	123	/	Average initial overclock for node C (ADUs)		
INITOCLD=	123	/	Average initial overclock for node D (ADUs)		
FITS binary table contents (one entry per event)					
#	TTYPE	TUNIT	TFORM	TLMAX	Comment
1	TIME	s	1D	n/a	S/C UTC corresponding to mid-exposure
2	EXPNO	n/a	1J	$2^{31}-1$	Exposure number since start of science run
3	CCDX	n/a	1I	1022	CCD column position of center pixel of event (TLMIN=1)
4	CCDY	n/a	1I	1022	CCD row position of center pixel of event (TLMIN=1)
5	RAW_PHAS	ADU	9I	4095	3x3 array of raw pixel pulse heights
6	BIAS	ADU	9I	4095	3x3 array of pixel bias map values

Table 13: TE Graded Event Data File (*_f_evtegb.fits)

Additional FITS Keyword Header Items					
FEP_ID =	2	/	Front End Processor ID:	0-5	
CCD_ID =	1	/	CCD id:	0 - 9	
FITS binary table contents (one entry per CCD exposure frame)					
FITS binary table contents (one entry per event)					
#	TTYPE	TUNIT	TFORM	TLMAX ^a	Comment
1	TIME	s	1D	n/a	S/C UTC corresponding to mid-exposure
2	EXPNO	n/a	1J	$2^{31}-1$	Exposure number since start of science run
3	CCDX	n/a	1I	1022	CCD column position of center pixel of event (TLMIN=1)
4	CCDY	n/a	1I	1022	CCD row position of center pixel of event (TLMIN=1)
5	PHA	ADU	1J	73710	Bias-corrected pulse-height of the 3x3 event
6	FLTGRADE	n/a	1I	255	Grade code of the event
7	CORN_PHA	ADU	1I	4095	Mean corrected pulse heights of corner pixels (TLMIN=-4096)

a. TLMIN is zero, except where noted.

Table 14: TE Very Faint Event Data File (*_f_evtevf.fits)

Additional FITS Keyword Header Items					
FEP_ID =		2 / Front End Processor ID: 0-5			
CCD_ID =		1 / CCD id: 0 - 9			
FITS binary table contents (one entry per event)					
#	TTYPE	TUNIT	TFORM	TLMAX	Comment
1	TIME	s	1D	n/a	S/C UTC corresponding to mid-exposure
2	EXPNO	n/a	1J	$2^{31}-1$	Exposure number since start of science run
3	CCDX	n/a	1I	1022	CCD column position of center pixel of event (TLMIN=1)
4	CCDY	n/a	1I	1022	CCD row position of center pixel of event (TLMIN=1)
5	RAW_PHAS	ADU	25I	4095	5x5 array of raw pixel pulse heights

4.4.7 Continuous Clocking Event Files

In one of the continuous-clocking modes, all X-ray events from a given FEP are written to one of the event files described in Tables 15–16. The EXPNO field serves as an index into the accompanying exposure record file.

Table 15: CC Faint Event Data File (*_f_evccf.fits)

Additional FITS Keyword Header Items					
FEP_ID =		2 / Front End Processor ID: 0-5			
CCD_ID =		1 / CCD id: 0 - 9			
FITS binary table contents (one entry per CCD exposure frame)					
Field	TTYPE	TUNIT	TFORM	TLMAX	Comment
1	TIME	s	1D	n/a	S/C UTC corresponding to row readout
2	EXPNO	n/a	1J	$2^{31}-1$	Exposure number since start of science run
3	TROW	n/a	1I	511	Transfer row counter of center pixel of event
4	CCDX	n/a	1I	1022	CCD column position of center pixel of event (TLMIN=1)
5	RAW_PHAS	ADU	3I	4095	1x3 array of raw pixel pulse heights

Table 16: CC Graded Event Data File (*_f_evccg.fits)

Additional FITS Keyword Header Items					
FEP_ID =		2 / Front End Processor ID: 0-5			
CCD_ID =		1 / CCD id: 0 - 9			
FITS binary table contents (one entry per CCD exposure frame)					
Field	TTYPE	TUNIT	TFORM	TLMAX	Comment
1	TIME	s	1D	n/a	S/C UTC corresponding to row readout

Field	TTYPE	TUNIT	TFORM	TLMAX	Comment
2	EXPNO	n/a	1J	$2^{31}-1$	Exposure number since start of science run
3	TROW	n/a	1I	511	Transfer row counter of center pixel of event
4	CCDX	n/a	1I	1022	CCD column position of center pixel of event (TLMIN=1)
5	PHA	ADU	1I	8190	Bias-corrected pulse-height of the 1x3 event
6	FLTGRADE	n/a	1I	15	Grade code of the event

4.4.8 Science Run Report File

Finally, each science run is summarized in a Report File (Table 17).

Table 17: Science Run Report File (*_srr.fits)

Additional FITS Keyword Header Items					
RUNSTART=	3924313546	/ Science Run Start in units of BEP clock			
PBLOCK	= '0x80000001'	/ Parameter Block Identifier			
WIND_ID	= '0xa0000001'	/ Window block Identifier			
BIASSTART=	3895671628	/ Bias Run Start in units of BEP ticks			
BIAS_ID	= '0x80000002'	/ PBLOCK for last bias calibration			
EXPTOT	= 335	/ total number of exposures produced			
EXPSENT	= 50	/ total number of exposures telemetered			
BERR_CNT=	0	/ number of pixel bias map errors detected			
DEA_ERRS=	0	/ errors detected on DEA Interface Board, 1 flag			
TERMCODE=	1	/ Code indicating the reason for the end of run			
SOFT_VER=	11	/ Instrument software version number			
FITS binary table contents (one entry per active FEP)					
Field	TTYPE	TUNIT	TFORM	TLMAX	Comment
1	FEP_ID	n/a	1I	5	FEP reporting error
2	CCD_ERRS	n/a	1I	1	code indicating errors on DEA during science run
3	FEP_ERRS	n/a	1I	255	code indicating errors on FEP during science run

4.4.9 Analog Housekeeping Files

All housekeeping telemetry received from the DEA analog boards and from the DEA interface controllers during a science run shall be decommutated by the Level 0 processing system and written to a DEA Housekeeping File (Table 18). The interpretation of DEA_VAL depends on the values of CCD_ID and QUERY_ID, as described in Appendix B.6.

Table 18: DEA Housekeeping File (*_deahk.fits)

Additional FITS Keyword Header Items	
RUNSTART=	3924313546 / Science Run Start in units of BEP clock
DEA_ID	= 3221225473 / DEA parameter block identifier (0xc0000001)
FITS binary table contents (one entry per reported DEA channel)	

Field	TTYPE	TUNIT	TFORM	TLMAX	Comment
1	DEA_CHAN	n/a	1I	256	DEA channel reporting value
2	SCETDIFF	s	1D	n/a	Time in seconds since start of observation (TSTART)
3	BEPCOUNT	0.1 s	1J	$2^{31}-1$	BEP timer tick interrupt counter value
4	CCD_ID	n/a	1I	10	CCD Identifier (0-9) to choose the corresponding DEA CCD Controller, or CCD_DESELECT (10) to choose the DEA interface board
5	QUERY_ID	n/a	1I	255	DEA query code sent to board (see Appendix B.6).
6	DEA_VAL	n/a	2B	65535	DEA Housekeeping value read from identified item. This value will contain 0xffff if the corresponding query to the DEA times out, or if the queried board is not powered on.

4.4.10 System Configuration Table Files

Should the system configuration table be downlinked to the telemetry stream during the science run¹, it will be written to a System Configuration file (Table 18). The numerous analog house-keeping channels are described in Applicable Document 4. Note that all columns of the binary table contain 16-bit unsigned fields.

Table 19: System Configuration File (*_sys.fits)

Additional FITS Keyword Header Items	
SCETDIFF=	1234.5 / Seconds (TAI) since TSTART
BEPCOUNT=	56789 / BEP timer tick interrupt counter value
DEA_PWR =	63 / DEA power indicator flags
FEP_PWR =	63 / FEP power indicator flags
MCLKDSAB=	1 / Master clock disable
FP_TEMP =	0 / Focal plane temperature
BAKETEMP=	0 / Bakeout temperature
BAKEENAB=	0 / Bakeout enable flag
LED_ENAB=	0 / LED enable flag
HHKPADDR=	0 / Hold housekeeping address
SIG_SEL =	0 / Signal path select
CCLKDSAB=	0 / COMmand clock disable flag
DCLKDSAB=	0 / Data clock disable flag
RELSET_0=	0 / Relay set 0
RELSET_1=	0 / Relay set 1
RELSET_2=	0 / Relay set 2
RELSET_3=	0 / Relay set 3
RELSET_4=	0 / Relay set 4

1. reported in a bepReadReply packet with formatTag of TTAG_DUMP_SYS_CONFIG (decimal 34).

FITS binary table contents — one entry per CCD/DEA						
Field	TTYPE	TUNIT	TFORM	TLMIN	TLMAX	Comment
1	CCD_ID	n/a	1I	0	10	CCD Identifier (0-9) to choose the corresponding DEA CCD Controller, or CCD_DESELECT (10) to choose the DEA interface board
2	SEQ_OFF	n/a	2B	0	65535	Sequencer Offset
3	VADC_OFF	n/a	2B	0	65535	Video ADC Offset
4	VCDSABM	n/a	2B	0	65535	Video Channel Disable Mask
5	HHKPADDR	n/a	2B	0	65535	Hold Housekeeping Address
6	BJD_ENAB	n/a	2B	0	65535	Back-Junction Diode Enable
7	HST_DSAB	n/a	2B	0	65535	High-speed tap disable
8	DAC_PIAP	n/a	2B	0	65535	Image Array Parallel +
9	DACPIAMP	n/a	2B	0	65535	Image Array Parallel -+
10	DAC_PIAM	n/a	2B	0	65535	Image Array Parallel -
11	DAC_PFSP	n/a	2B	0	65535	Framestore Parallel +
12	DACPFSP	n/a	2B	0	65535	Framestore Parallel -+
13	DAC_PFSM	n/a	2B	0	65535	Framestore Parallel -
14	DAC_S_P	n/a	2B	0	65535	Serial Register +
15	DAC_S_M	n/a	2B	0	65535	Serial Register -
16	DAC_R_P	n/a	2B	0	65535	Reset Gate +
17	DAC_R_MP	n/a	2B	0	65535	Reset Gate -+
18	DAC_R_M	n/a	2B	0	65535	Reset Gate -
19	DAC_SCP	n/a	2B	0	65535	Scupper
20	DAC_OG_P	n/a	2B	0	65535	Output Gate +
21	DAC_OG_M	n/a	2B	0	65535	Output Gate -
22	DAC_RD	n/a	2B	0	65535	Reset Diode
23	DAC_DR0	n/a	2B	0	65535	Drain Output (A)
24	DAC_DR1	n/a	2B	0	65535	Drain Output (B)
25	DAC_DR2	n/a	2B	0	65535	Drain Output (C)
26	DAC_DR3	n/a	2B	0	65535	Drain Output (D)
27	DAC_AOFF	n/a	2B	0	65535	A channel offset
28	DAC_BOFF	n/a	2B	0	65535	B channel offset
29	DAC_COFF	n/a	2B	0	65535	C channel offset
30	DAC_DOFF	n/a	2B	0	65535	D channel offset

4.5 Bias Map Formats

Unique among the Level 0 products, the bias map files do not contain FITS binary table extensions. Instead, they use the FITS convention to describe 2-dimensional image arrays. Timed-exposure bias maps (Table 20) will always contain 1024x1024 pixels, and continuous-clocking bias maps (Table 21) will contain 1024x512 pixels. These formats apply even when less than a full CCD is read out (TE sub-array mode), or when pixels are summed on-chip (2x2 summation in TE mode, column and/or row summation in CC mode).

“Good” bias map pixel values are in the range 0-4093. Pixels belonging to the current bad-pixel or bad-column lists, and pixels lying outside the area read out in sub-array mode, will be assigned the value `PIXEL_BAD` (decimal 4095). Pixels that have caused parity errors during a science run before the bias map was copied to the telemetry stream will be assigned the value `BIAS_BAD` (decimal 4094).

Table 20: TE Bias Map File (*_f_tebias.fits)

FITS Keyword Header	
<code>SIMPLE</code>	= T / FITS STANDARD
<code>BITPIX</code>	= 16 / 16-bit image pixels
<code>NAXIS</code>	= 2 / 2-dimensional image
<code>NAXIS1</code>	= 1024 / Number of pixels per row
<code>NAXIS2</code>	= 1024 / Number of rows (=512 for CC maps)
<code>COMMENT</code>	
<code>COMMENT</code>	AXAF FITS TE Bias File: ACIS Level 0
<code>COMMENT</code>	
<code>MISSION</code>	= 'AXAF' / Advanced X-ray Astrophysics Facility
<code>TELESCOP</code>	= 'AXAF' / Telescope used
<code>INSTRUME</code>	= 'ACIS' / AXAF CCD Imaging Spectrometer
<code>DATE-OBS</code>	= '25/02/97' / Date of observation start
<code>TIME-OBS</code>	= '20:00:00' / Time of observation start
<code>MJD-OBS</code>	= 58904.84293 / MJD of observation start
<code>CREATOR</code>	= 'psci 2.3' / Program creating this file
<code>ASCVER</code>	= 'ACIS_L0_2.0' / Format spec for this file
<code>ORIGIN</code>	= 'ASC' / Organization creating file
<code>DATE</code>	= '26/02/96' / Date file was created
<code>REVISION</code>	= 0 / Processing revision
<code>EVENT</code>	= 'EVENTS' / PROS: Name of extension with events
<code>DATACLASS</code>	= 'OBSERVED' / Data is observed, not simulated
<code>MJDREFI</code>	= 50814 / MJD of clock start
<code>MJDREFF</code>	= 0.000731296 / 63.184/86400
<code>TSTART</code>	= 825365629.0 / Observation start time, seconds
<code>TELAPSE</code>	= 1218.0 / Elapsed time, seconds
<code>TIMEUNIT</code>	= 's' / HEASARC: time unit
<code>TIMESYS</code>	= '1998.0' / HEASARC: time system

Table 20: TE Bias Map File (*_f_tebias.fits) (Continued)

FITS Keyword Header	
TIMEDEL =	0.200000003 / Smallest meaningful time increment, s
TIMEREf =	'LOCAL ' / Time is local for data
TIMVERSN=	'OGIP/93-003a' / OGIP time convention
TASSIGN =	'SATELLITE ' / Source of time assignment
COMMENT	
COMMENT	AXAF FITS TE Bias File: Special ACIS Keywords
COMMENT	
READMODE=	'TIMED ' / CCD exposure mode
DATAMODE=	'FAINT ' / CCD telemetry mode
RUN_ID =	1 / Science run index
STARTBEP=	0 / BEP timer value at TSTART
STOPBEP=	0 / BEP timer value at TSTOP
STARTMJF=	0 / Maj frame containing start of Sci Run
STARTMNF=	0 / Min frame containing start of Sci Run
STOPMJF =	0 / Maj frame containing end of Sci Run
STOPMNF =	0 / Min frame containing end of Sci Run
FEP_ID =	0 / FEP id: 0 - 5
CCD_ID =	7 / CCD id: 0 - 9
CCDROW1 =	1 / Index of first CCD row
CCDNROWS=	1024 / Number of CCD rows
CCDNODES=	4 / Number of CCD output nodes
ORC_MODE=	0 / CCD readout mode
SUM2X2 =	0 / Pixel summation: YES or NO
DEAGAIN =	0 / Video gain setting: 0:high, 1:low
BIASALG =	1 / Bias algorithm parameter
BIASARG0=	5 / Bias argument 1
BIASARG1=	16 / Bias argument 2
BIASARG2=	0 / Bias argument 3
BIASARG3=	26 / Bias argument 4
BIASARG4=	20 / Bias argument 5
INITOCLA=	794 / Average initial overclock for node A
INITOCLB=	553 / Average initial overclock for node B
INITOCLC=	700 / Average initial overclock for node C
INITOCLD=	655 / Average initial overclock for node D
END	
followed by padding sufficient to make the header a multiple of 36 lines (2880 bytes)	
FITS image array	
1024 x 1024 (TE) or 1024 X 512 (CC) image pixels—16-bit integers	

Table 21: CC Bias Map File (*_f_ccbias.fits)

FITS Keyword Header	
SIMPLE	= T / FITS STANDARD
BITPIX	= 16 / 16-bit image pixels
NAXIS	= 2 / 2-dimensional image
NAXIS1	= 1024 / Number of pixels per row
NAXIS2	= 1024 / Number of rows (=512 for CC maps)
COMMENT	
COMMENT	AXAF FITS CC Bias File: ACIS Level 0
COMMENT	
MISSION	= 'AXAF' / Advanced X-ray Astrophysics Facility
TELESCOP	= 'AXAF' / Telescope used
INSTRUME	= 'ACIS' / AXAF CCD Imaging Spectrometer
DATE-OBS	= '25/02/97' / Date of observation start
TIME-OBS	= '20:00:00' / Time of observation start
MJD-OBS	= 58904.84293 / MJD of observation start
CREATOR	= 'psci 2.3' / Program creating this file
ASCVER	= 'ACIS_L0_2.0' / Format spec for this file
ORIGIN	= 'ASC' / Organization creating file
DATE	= '26/02/96' / Date file was created
REVISION	= 0 / Processing revision
EVENT	= 'EVENTS' / PROS: Name of extension with events
DATACLASS	= 'OBSERVED' / Data is observed, not simulated
MJDREFI	= 50814 / MJD of clock start
MJDREFF	= 0.000731296 / 63.184/86400
TSTART	= 825365629.0 / Observation start time, seconds
TELAPSE	= 1218.0 / Elapsed time, seconds
TIMEUNIT	= 's' / HEASARC: time unit
TIMESYS	= '1998.0' / HEASARC: time system

Table 21: CC Bias Map File (*_f_ccbias.fits) (Continued)

FITS Keyword Header	
TIMEDEL =	0.200000003 / Smallest meaningful time increment, s
TIMEREf =	'LOCAL ' / Time is local for data
TIMVERSN=	'OGIP/93-003a' / OGIP time convention
TASSIGN =	'SATELLITE ' / Source of time assignment
COMMENT	
COMMENT	AXAF FITS CC Bias File: Special ACIS Keywords
COMMENT	
READMODE=	'CONTINUOUS' / CCD exposure mode
DATAMODE=	'FAINT ' / CCD telemetry mode
RUN_ID =	1 / Science run index
STARTBEP=	0 / BEP timer value at TSTART
STOPBEP=	0 / BEP timer value at TSTOP
STARTMJF=	0 / Maj frame containing start of Sci Run
STARTMNF=	0 / Min frame containing start of Sci Run
STOPMJF =	0 / Maj frame containing end of Sci Run
STOPMNF =	0 / Min frame containing end of Sci Run
FEP_ID =	0 / FEP id: 0 - 5
CCD_ID =	7 / CCD id: 0 - 9
CCDNODES=	4 / Number of CCD output nodes
SUMROW =	0 / Number of CCD rows to sum (powers of 2)
SUMCOL =	0 / Number of CCD columns to sum (powers of 2)
ORC_MODE=	0 / CCD readout mode
DEAGAIN =	0 / Video gain setting: 0:high, 1:low
BIASALG =	1 / Bias algorithm id. 1:whole frame; 2:strip
BIASREJ =	1 / Bias rejection parameter
INITOCLA=	794 / Average initial overclock for node A
INITOCLB=	553 / Average initial overclock for node B
INITOCLC=	700 / Average initial overclock for node C
INITOCLD=	655 / Average initial overclock for node D
END	
followed by padding sufficient to make the header a multiple of 36 lines (2880 bytes)	
FITS image array	
1024 x 1024 (TE) or 1024 X 512 (CC) image pixels—16-bit integers	

4.6 Volume, Size, and Frequency Estimates

TBD.

Appendix A: IP&CL Fields and MSID Keywords

Table A–1: Traceability between ACIS IP&CL fields and MSID keywords

IP&CL Field Name ^a	Dim ^b	Len ^c	<i>m</i> ^d	Keyword ^e	Description
bepStartupMessage	MSID=SCI_BEP_STARTUP_m				Startup Message emitted by software upon reset of BEP
bepStartupMessage.bepTickCounter	1	32	0	BEP_COUNT	Back End Timer Tick interrupt counter value at about time packet is posted to telemetry
bepStartupMessage.version	1	32	1	SOFT_VER	Instrument software version number
dataBiasError	MSID=SCI_BIAS_ERR_m				Bias Error Data Packet from a FEP
dataBiasError.biasStartTime	1	32	0	BIAS_START	Science timestamp counter value at start of the bias computation
dataBiasError.biasParameterId	1	32	1	BIAS_ID	Bias Run's Parameter Block's Identifier field
dataBiasError.ccdId	1	4	2	CCD_ID	Identify which CCD produced the error(s) [§B.1]
dataBiasError.fepId	1	3	3	FEP_ID	Identify which FEP computed the error(s) [§B.4]
dataBiasError.biasErrors[n].row	n	10	4	CCDY	Bias Map row containing the bias error
dataBiasError.biasErrors[n].column	n	10	5	CCDX	Bias Map column containing the bias error
dataBiasError.biasErrors[n].value	n	12	6	BIAS	Bias Map value which produced the error
dataCcBiasMap	MSID=SCI_CC_BIAS_m				Portion of a Continuous Clocking Bias Map from one FEP
dataCcBiasMap.biasStartTime	1	32	0	BIAS_START	Science timestamp counter value at start of bias computation
dataCcBiasMap.biasParameterId	1	32	1	BIAS_ID	Bias Run's Parameter Block's Identifier field
dataCcBiasMap.ccdId	1	4	2	CCD_ID	Identify which CCD produced the data [§B.1]
dataCcBiasMap.fepId	1	3	3	FEP_ID	Identify which FEP computed the data [§B.4]
dataCcBiasMap.initialOverclocks[4]	4	16	4–7	INITOCLK	Output node initial overclock values added to pixel map values (in Full/Diag Mode, ordered by node [A,B,C,D]. In AC mode, [A,C,x,x] and in BD Mode, [B,D,x,x])
dataCcBiasMap.data[1024]	1024	12 ^f	8	n/a	Array of 12-bit bias values, one for each column bias value. Indexed linearly starting from column 0.
dataCcFaint	MSID=SCI_CC_DAT_FAINT_m				Data Packet, Continuous Clocking, Faint Mode
dataCcFaint.ccdId	1	4	0	CCD_ID	Identify which CCD produced the data [§B.1]
dataCcFaint.fepId	1	3	1	FEP_ID	Identify which FEP processed the data [§B.4]
dataCcFaint.events[n].transferRow	n	9	3	TROW	Transfer Row counter (relative to start of frame) of center pixel of the event
dataCcFaint.events[n].ccdColumn	n	10	4	CCDX	CCD Column position of center pixel of the event
dataCcFaint.events[n].pulseHeights[3]	3*n	16	5	RAW_PHAS	Array of Raw Pixel Pulse Heights columns -1, 0, 1

Table A-1: Traceability between ACIS IP&CL fields and MSID keywords (Continued)

IP&CL Field Name ^a	Dim ^b	Len ^c	m ^d	Keyword ^e	Description
dataCcGraded	MSID=SCI_CC_DAT_GRADED_n			Data Packet, Continuous Clocking, Graded Mode	
dataCcGraded.ccdId	1	4	0	CCD_ID	Identify which CCD produced the data [§B.1]
dataCcGraded.fepId	1	3	1	FEP_ID	Identify which FEP processed the data [§B.4]
dataCcGraded.events[n].transferRow	n	9	3	TROW	Transfer Row counter (relative to start of frame) of center pixel of the event
dataCcGraded.events[n].ccdColumn	n	10	4	CCDX	CCD Column position of center pixel of the event
dataCcGraded.events[n].eventAmplitude	n	13	5	PHA	Amplitude of the 1x3 Event
dataCcGraded.events[n].gradeCode	n	2	6	FLTGRADE	Graded Code of the event [§B.3]
dataTeBiasMap	MSID=SCI_TE_BIAS_m			Portion of a Timed Exposure Bias Map from one FEP	
dataTeBiasMap.biasStartTime	1	32	0	BIASTART	Science timestamp counter value at start of bias computation
dataTeBiasMap.biasParameterId	1	32	1	BIAS_ID	Bias Run's Parameter Block's Identifier field
dataTeBiasMap.ccdId	1	4	2	CCD_ID	Identify which CCD produced the data [§B.1]
dataTeBiasMap.fepId	1	3	3	FEP_ID	Identifies which FEP computed and used the bias map [§B.4]
dataTeBiasMap.initialOverclocks[4]	4	16	5-8	INITOCLK	Output node initial overclock values added to pixel map values (In Full/Diag Mode, nodes are ordered as [A,B,C,D]. In AC mode, [A,C,x,x], and in BD mode [B,D,x,x])
dataTeBiasMap.pixelsPerRow	1	10	9	NUMCOLS	Total number of pixels in each bias row minus 1 (i.e. 0 corresponds to 1 pixel)
dataTeBiasMap.rowsPerBias	1	10	10	NUMROWS	Total number of rows in bias image minus 1 (i.e. 0 corresponds to 1 row)
dataTeBiasMap.ccdRow	1	10	11	n/a	CCD Row position of first pixel in data packet
dataTeBiasMap.ccdRowCount	1	10	12	n/a	Number of rows compressed into this data packet minus 1
dataTeBiasMap.compressionTableSlotIndex	1	8	13	BCMPSLOT	Slot index of Compression Table Identifier used to pack data (255 no compression)
dataTeBiasMap.compressionTableIdentifier	1	32	14	HUFF_ID	Identifier stored within Huffman Compression Table used to pack data (0 if no compression)
dataTeBiasMap.pixelCount	1	32	15	n/a	The total number of pixels packed into the packet
dataTeBiasMap.data[n]	n	12 ^f	16	n/a	Compressed bias map data values (12-bits/uncompressed value). Indexed by column, starting from 0. Rows sent in reverse order (farthest from Framestore first)
dataTeFaint	MSID=SCI_TE_DAT_FAINT_m			Data Packet, Timed Exposure, Faint Mode	
dataTeFaint.ccdId	1	4	0	CCD_ID	Identify which CCD produced the data [§B.1]

Table A-1: Traceability between ACIS IP&CL fields and MSID keywords (Continued)

IP&CL Field Name ^a	Dim ^b	Len ^c	m ^d	Keyword ^e	Description
dataTeFaint.fepId	1	3	1	FEP_ID	Identify which FEP processed the data [§B.4]
dataTeFaint.events[n].ccdRow	n	10	3	CCDY	CCD Row position of center pixel of the event
dataTeFaint.events[n].ccdColumn	n	10	4	CCDX	CCD Column position of center pixel of the event
dataTeFaint.events[n].pulseHeights[9]	9*n	12	5	RAW_PHAS	Array of Raw Pixel Pulse Heights ((row, column) (-1,-1),(-1,0),(-1,1),(0,-1), ...)
dataTeFaintBias	MSID=SCI_TE_DAT_FAINTB_m			Data Packet, Timed Exposure, Faint Mode with Bias	
dataTeFaintBias.ccdId	1	4	0	CCD_ID	Identify which CCD produced the data [§B.1]
dataTeFaintBias.fepId	1	3	1	FEP_ID	Identify which FEP processed the data [§B.4]
dataTeFaintBias.events[n].ccdRow	n	10	3	CCDY	CCD Row position of center pixel of the event
dataTeFaintBias.events[n].ccdColumn	n	10	4	CCDX	CCD Column position of center pixel of the event
dataTeFaintBias.events[n].pulseHeights[9]	9*n	12	5	RAW_PHAS	Array of Raw Pixel Pulse Heights ((row, column) (-1,-1),(-1,0),(-1,1),(0,-1), ...)
dataTeFaintBias.events[n].biasValues[9]	9*n	12	6	BIAS	Array of Pixel Bias Map Values ((row, column) (-1,-1),(-1,0),(-1,1),(0,-1), ...)
dataTeGraded	MSID=SCI_TE_DAT_GRADED_m			Data Packet, Timed Exposure, Graded Mode	
dataTeGraded.ccdId	1	4	0	CCD_ID	Identify which CCD produced the data [§B.1]
dataTeGraded.fepId	1	3	1	FEP_ID	Identify which FEP processed the data [§B.4]
dataTeGraded.events[n].ccdRow	n	10	3	CCDY	CCD Row position of center pixel of the event
dataTeGraded.events[n].ccdColumn	n	10	4	CCDX	CCD Column position of center pixel of the event
dataTeGraded.events[n].eventAmplitude	n	17	5	PHA	Total corrected amplitude of the event
dataTeGraded.events[n].gradeCode	n	8	6	FLTGRADE	Grade code of the event [§B.3]
dataTeGraded.events[n].cornerMean	n	13	7	CORN_PHA	Mean of the corrected pulse height value of corner pixels within the event, rounded to the nearest integer value. If no corner values were valid, this field will contain 4095. If the mean is less than or equal to -4096, the field will be set to -4096
dataTeVeryFaint	MSID=SCI_TE_DAT_VFAINT_m			Data Packet, Timed Exposure, Faint Mode 5x5	
dataTeVeryFaint.ccdId	1	4	0	CCD_ID	Identify which CCD produced the data [§B.1]
dataTeVeryFaint.fepId	1	3	1	FEP_ID	Identify which FEP processed the data [§B.4]
dataTeVeryFaint.events[n].ccdRow	n	10	3	CCDY	CCD Row position of center pixel of the event
dataTeVeryFaint.events[n].ccdColumn	n	10	4	CCDX	CCD Column position of center pixel of the event (NOTE: Events reported in Column 1 contain garbage in the pixel column 0. Events reported in Column 1022 contain garbage in pixel column 4.)

Table A-1: Traceability between ACIS IP&CL fields and MSID keywords (Continued)

IP&CL Field Name ^a	Dim ^b	Len ^c	m ^d	Keyword ^e	Description
dataTeVVeryFaint.events[n].pulseHeights[25]	25*n	12	5	RAW_PHAS	Array of Raw Pixel Pulse Heights ((row, column) (-2,-2),(-2,-1),(-2,0),(-2,1),(-2,2),(-1,-2) ...)
deaHousekeepingData	MSID=SCI_DEA_HOUSE_m			DEA Housekeeping Values	
deaHousekeepingData.deaBlockId	1	32	0	DEA_ID	DEA Parameter Block Identifier
deaHousekeepingData.bepTickCounter	1	32	2	BEP_COUNT	Back End Timer Tick interrupt counter value (0.1 seconds since last BEP reset) at start of data accumulation
deaHousekeepingData.entries[n].ccdId	n	8	3	CCD_ID	CCD Identifier (0-9) to choose the corresponding DEA CCD Controller, or CCD_DESELECT (10) to choose the DEA interface board. [§B.1]
deaHousekeepingData.entries[n].queryId	n	8	4	QUERY_ID	DEA query code sent to board [§B.6]
deaHousekeepingData.entries[n].value	n	16	5	DEA_VAL	DEA Housekeeping value read from identified item. This value will contain 0xffff if the corresponding query to the DEA times out, or if the queried board is not powered on.
exposureCcFaint	MSID=SCI_CC_REC_FAINT_m, SCI_CC_REC_GRADED_m			Exposure Record, Continuous Clocking, Faint and Graded Mode	
exposureCcFaint.runStartTime	1	32	0	RUNSTART	Science timestamp counter value at start of science run
exposureCcFaint.parameterBlockId	1	32	1	PBLOCK	Parameter Block's Identifier field
exposureCcFaint.windowBlockId	1	32	2	WIND_ID	Window List Parameter Block's Identifier field (0xffffffff if none used)
exposureCcFaint.biasStartTime	1	32	3	BIASSTART	Science timestamp counter value at start of bias computation
exposureCcFaint.biasParameterId	1	32	4	BIAS_ID	Parameter Block Identifier from most recent bias computation
exposureCcFaint.ccdId	1	4	5	CCD_ID	Identify which CCD produced the data [§B.1]
exposureCcFaint.fepId	1	3	6	FEP_ID	Identify which FEP processed the data [§B.4]
exposureCcFaint.fepTimestamp	1	25	7	FEPSTAMP	FEP Timestamp when FEP received Beginning of Frame mark
exposureCcFaint.exposureNumber	1	32	8	EXPNO	Exposure Number since start of run (of the data just received)
exposureCcFaint.eventsSent	1	32	9	EVTSENT	Number of events telemetered in preceding set of data records
exposureCcFaint.thresholdPixels	1	32	10	THR_PIX	Number of pixels detected above their respective threshold levels
exposureCcFaint.discardEventAmplitude	1	32	11	DROP_AMP	Number of events discarded due to their corrected amplitude
exposureCcFaint.discardWindow	1	32	12	DROP_POS	Number of events discarded due to their CCD position
exposureCcFaint.discardGrade	1	32	13	DROP_GRD	Number of events discarded due to their Grade Code

Table A-1: Traceability between ACIS IP&CL fields and MSID keywords (Continued)

IP&CL Field Name ^a	Dim ^b	Len ^c	m ^d	Keyword ^e	Description
exposureCcFaint.deltaOverclocks[4]	4	16 ^g	14	DELTOCLK	Output node Delta Overclock values used for the completed exposure (delta = (exposure overclock) - (initial overclock)) (NOTE: In Full/Diag modes, the nodes are indexed as follows [A,B,C,D]. In AC mode, the nodes are [A,C,x,x]. In BD mode, the nodes are [B,D,x,x].
exposureCcFaint.biasParityErrors	1	32	15	BERR_SUM	Total number of pixel bias errors so far in the run
exposureTeFaint	MSID=SCI_TE_REC_FAINT_m, SCI_TE_REC_GRADED_m, SCI_TE_REC_VFAINT_m			Exposure Record, Timed Exposure, Faint, Very Faint, & Graded Modes	
exposureTeFaint.runStartTime	1	32	0	RUNSTART	Science timestamp counter value at start of science run
exposureTeFaint.parameterBlockId	1	32	1	PBLOCK	Parameter Block's Identifier field
exposureTeFaint.windowBlockId	1	32	2	WIND_ID	Window List Parameter Block's Identifier field (0xffffffff if none used)
exposureTeFaint.biasStartTime	1	32	3	BIASTART	Science timestamp counter value at start of bias computation
exposureTeFaint.biasParameterId	1	32	4	BIAS_ID	Parameter Block Identifier from most recent bias computation
exposureTeFaint.ccdId	1	4	5	CCD_ID	Identify which CCD produced the data [§B.1]
exposureTeFaint.fepId	1	3	6	FEP_ID	Identify which FEP processed the data [§B.4]
exposureTeFaint.fepTimestamp	1	25	7	FEPSTAMP	Fep Timestamp when FEP received Beginning of Frame mark
exposureTeFaint.exposureNumber	1	32	8	EXPNO	Exposure Number since start of run (of the data just received)
exposureTeFaint.eventsSent	1	32	9	EVTSENT	Number of events telemetered in preceding set of data records
exposureTeFaint.thresholdPixels	1	32	10	THR_PIX	Number of pixels detected above their respective threshold levels
exposureTeFaint.discardEventAmplitude	1	32	11	DROP_AMP	Number of events discarded due to their corrected amplitude
exposureTeFaint.discardWindow	1	32	12	DROP_POS	Number of events discarded due to their CCD position
exposureTeFaint.discardGrade	1	32	13	DROP_GRD	Number of events discarded due to their Grade Code
exposureTeFaint.deltaOverclocks[4]	4	16 ^g	14	DELTOCLK	Output node Delta Overclock values used for the completed exposure (delta = (exposure overclock) - (initial overclock)) (NOTE: In Full/Diag modes, the nodes are indexed as follows [A,B,C,D]. In AC mode, the nodes are [A,C,x,x]. In BD mode, the nodes are [B,D,x,x].
exposureTeFaint.biasParityErrors	1	32	15	BERR_SUM	Total number of pixel bias errors so far in the run
exposureTeFaintBias	MSID=SCI_TE_REC_FAINTB_m			Exposure Record, Timed Exposure, Faint with Bias Mode	
exposureTeFaintBias.runStartTime	1	32	0	RUNSTART	Science timestamp counter value at start of science run
exposureTeFaintBias.parameterBlockId	1	32	1	PBLOCK	Parameter Block's Identifier field

Table A-1: Traceability between ACIS IP&CL fields and MSID keywords (Continued)

IP&CL Field Name ^a	Dim ^b	Len ^c	m ^d	Keyword ^e	Description
exposureTeFaintBias.windowBlockId	1	32	2	WIND_ID	Window List Parameter Block's Identifier field (0xffffffff if none used)
exposureTeFaintBias.biasStartTime	1	32	3	BIASTART	Science timestamp counter value at start of bias computation
exposureTeFaintBias.biasParameterId	1	32	4	BIAS_ID	Parameter Block Identifier from most recent bias computation
exposureTeFaintBias.ccdId	1	4	5	CCD_ID	Identify which CCD produced the data [§B.1]
exposureTeFaintBias.fepId	1	3	6	FEP_ID	Identify which FEP processed the data [§B.4]
exposureTeFaintBias.fepTimestamp	1	25	7	FEPSTAMP	FEP Timestamp when FEP received Beginning of Frame mark
exposureTeFaintBias.exposureNumber	1	32	8	EXPNO	Exposure Number since start of run (of the data just received)
exposureTeFaintBias.eventsSent	1	32	9	EVTSENT	Number of events telemetered in preceding set of data records
exposureTeFaintBias.thresholdPixels	1	32	10	THR_PIX	Number of pixels detected above their respective threshold levels
exposureTeFaintBias.discardEventAmplitude	1	32	11	DROP_AMP	Number of events discarded due to their corrected amplitude
exposureTeFaintBias.discardWindow	1	32	12	DROP_POS	Number of events discarded due to their CCD position
exposureTeFaintBias.discardGrade	1	32	13	DROP_GRD	Number of events discarded due to their Grade Code
exposureTeFaintBias.deltaOverclocks[4]	4	16 ^g	14	DELTOCLK	Output node Delta Overclock values used for the completed exposure (delta = (exposure overclock) - (initial overclock)) (NOTE: In Full/Diag modes, the nodes are indexed as follows [A,B,C,D]. In AC mode, the nodes are [A,C,x,x]. In BD mode, the nodes are [B,D,x,x].
exposureTeFaintBias.biasParityErrors	1	32	15	BERR_SUM	Total number of pixel bias errors so far in the run
exposureTeFaintBias.initialOverclocks[4]	4	16	16	INITOCLK	Output node initial overclock values added to pixel map values (In Full/Diag Mode, nodes are ordered [A,B,C,D]. In AC mode, [A,C,x,x], and in BD mode, [B,D,x,x])
dumpedCcBlock.load1dBlock	MSID=DUMP_CC_m (windows)			Load 1-D Window List Parameter Block	
load1dBlock.windowBlockId	1	32	50	WIND_ID	Identifies the 1D Window List Parameter Block
load1dBlock.windows[n].ccdId	n	4	51	CCD_ID	Selects to which CCD the window processes [§B.1]
load1dBlock.windows[n].ccdColumn	n	10	52	LL_CCDX	Selects the lowest CCD column index covered by the window
load1dBlock.windows[n].width	n	10	53	WIN_COLS	Selects the number of CCD Columns covered by the window (# of columns minus 1)
load1dBlock.windows[n].sampleCycle	n	8	54	WIN_ROWS	Selects how many events to skip between each accepted event
load1dBlock.windows[n].lowerEventAmplitude	n	12	55	PHAMIN	Selects the minimum event amplitude accepted by the window
load1dBlock.windows[n].eventAmplitudeRange	n	16	56	PHARANGE	Range of event amplitudes accepted by the window filter.
dumpedTeBlock.load2dBlock	MSID=DUMP_TE_m (windows)			Load 2-D Window List Parameter Block	

Table A-1: Traceability between ACIS IP&CL fields and MSID keywords (Continued)

IP&CL Field Name ^a	Dim ^b	Len ^c	<i>m</i> ^d	Keyword ^e	Description
load2dBlock.windowBlockId	1	32	61	WIND_ID	Identifies the 2D Window List Parameter Block
load2dBlock.windows[n].ccdId	n	4	62	CCD_ID	Selects to which CCD the window processes [§B.1]
load2dBlock.windows[n].ccdRow	n	10	63	LL_CCDY	Selects the lowest CCD row index covered by the window
load2dBlock.windows[n].ccdColumn	n	10	64	LL_CCDX	Selects the lowest CCD column index covered by the window
load2dBlock.windows[n].width	n	10	65	WIN_COLS	Selects the number of CCD Columns covered by the window (# of columns minus 1)
load2dBlock.windows[n].height	n	10	66	WIN_ROWS	Selects the number of CCD Rows covered by the window (# of rows minus 1)
load2dBlock.windows[n].sampleCycle	n	8	67	SAMP_CYC	Selects how many events to skip between each accepted event
load2dBlock.windows[n].lowerEventAmplitude	n	12	68	PHAMIN	Selects the minimum event amplitude accepted by the window
load2dBlock.windows[n].eventAmplitudeRange	n	16	69	PHARANGE	Range of event amplitudes accepted by the window filter.
dumpedCcBlock.loadCcBlock	MSID=DUMP_CC_m			Load Continuous Clocking Parameter Block	
loadCcBlock.parameterBlockId	1	32	5	PBLOCK	Identifies the Continuous Clocking Parameter Block
loadCcBlock.fepCcdSelect[6]	6	4	6	CCD_ID	Array of Ccd Selections indexed by FEP Id. This identifies a CCD, where values 0 through 9 respectively select CCDs I0-I3 and S0-S5, and 10 acts as a deselect. [§B.1]
loadCcBlock.fepMode	1	4	7	FEP_MODE	Front End Selection Algorithm [§B.9.2]
loadCcBlock.bepPackingMode	1	4	8	BEP_MODE	Event List Packing Code [§B.10.2]
loadCcBlock.ignoreBadColumnMap	1	1	9	NOBADCOL	Disable use of Continuous Clocking Bad Column Map (0:Use, 1:Don't use)
loadCcBlock.recomputeBias	1	1	10	BIAS_CAL	Enable bias calibration when used for data run (0: Don't compute, 1:Compute)
loadCcBlock.trickleBias	1	1	11	SENDBIAS	Telemeter re-computed bias (0: Don't send, 1:Send)
loadCcBlock.rowSum	1	4	12	SUMROW	Number of CCD rows to sum in powers of 2
loadCcBlock.columnSum	1	4	13	SUMCOL	Number of CCD columns to sum in powers of 2
loadCcBlock.overclockPairsPerNode	1	4	14	OCLKPAIR	Number of pairs of (possibly summed) overclock pixels (per output node)
loadCcBlock.outputRegisterMode	1	2	15	ORC_MODE	Output Register Mode [§B.5]
loadCcBlock.ccdVideoResponse[6]	6	1	16	VIDRESP	Array of CCD video responses, indexed by FEP Id. In cases of conflict, the last entry wins. This selects the video chain response for a given CCD. 0 indicates 1:1, and 1 indicates a 1:4 response
loadCcBlock.fepEventThreshold[6][4]	6*4	16 ^g	17-22	EVT_THR	Threshold set points for each output node coming into Fep 0

Table A-1: Traceability between ACIS IP&CL fields and MSID keywords (Continued)

IP&CL Field Name ^a	Dim ^b	Len ^c	m ^d	Keyword ^e	Description
loadCcBlock.fepSplitThreshold[6][4]	6*4	16	23-28	SPL_THR	Split Threshold set points for each output node coming into Fep 0
loadCcBlock.lowerEventAmplitude	1	16	29	PHAMIN	Minimum accepted event amplitude (pulse height filter)
loadCcBlock.eventAmplitudeRange	1	16	30	PHARANGE	Range of event amplitudes accepted by the pulse height filter.
loadCcBlock.gradeSelections[4]	4	1	31	GRADEMAP	Bitfield of accepted event grade code flags, indexed by grade code [§B.3]
loadCcBlock.rawCompressionSlotIndex	1	8	33	RCMPSLOT	Slot identifier of Compression table for raw mode from all FEPs (255 = no compression)
loadCcBlock.ignoreInitialFrames	1	16	34	EXP_SKIP	The number of whole exposure frames that the FEP is to ignore at the start of a bias calibration. If zero, accept all valid data after the first VSYNC.
loadCcBlock.biasAlgorithmId[6]	6	8	35	BIASALG	Selects bias algorithm to use for indexed FEP [§B.7.2]
loadCcBlock.biasRejection[6]	6	16	36	BIASREJ	Bias rejection parameter for indexed FEP [§B.7.2]
loadCcBlock.fepVideoOffset[6][4]	6*4	16	37-42	VID_OFF	Video Offset values for each output node coming into FEP 0
loadCcBlock.deaLoadOverride	1	32	43	DEALOAD	If not zero, pointer to explicit DEA Load in RAM
loadCcBlock.fepLoadOverride	1	32	44	FEPLOAD	If not zero, pointer to explicit FEP Load in RAM
dumpedTeBlock.loadTeBlock	MSID=DUMP_TE_m			Load Timed Exposure Parameter Block	
loadTeBlock.parameterBlockId	1	32	5	PBLOCK	Identifies the Timed Exposure Parameter Block
loadTeBlock.fepCcdSelect[6]	6	4	6	CCD_ID	Array of Ccd Selections indexed by FEP Id. This identifies a CCD, where values 0 through 9 respectively select CCDs I0-I3 and S0-S5, and 10 acts as a deselect. [§B.1]
loadTeBlock.fepMode	1	4	7	FEP_MODE	Front End Algorithm selection [§B.9.1]
loadTeBlock.bepPackingMode	1	4	8	BEP_MODE	Event List Packing Code [§B.10.1]
loadTeBlock.onChip2x2Summing	1	1	9	SUM_2X2	On-chip summing selection (0: none, 1: sum 2x2)
loadTeBlock.ignoreBadPixelMap	1	1	10	NOBADPIX	Disable use of Bad Pixel Map (0: Use, 1:Ignore Map)
loadTeBlock.ignoreBadColumnMap	1	1	11	NOBADCOL	Disable use of Timed Exposure Bad Column Map (0:Use, 1:Ignore Map)
loadTeBlock.recomputeBias	1	1	12	BIAS_CAL	Enable bias calibration when used for data run (0:Don't compute, 1:Compute)
loadTeBlock.trickleBias	1	1	13	SENDBIAS	Telemeter re-computed bias (0: Don't send, 1:Send)
loadTeBlock.subarrayStartRow	1	10	14	STARTROW	Index of first (possibly summed) row to clock out of the CCDs
loadTeBlock.subarrayRowCount	1	10	15	ROWCNT	One less than the number of (possibly summed) rows to clock out of the CCD

Table A-1: Traceability between ACIS IP&CL fields and MSID keywords (Continued)

IP&CL Field Name ^a	Dim ^b	Len ^c	<i>m</i> ^d	Keyword ^e	Description
loadTeBlock.overclockPairsPerNode	1	4	16	OCLKPAIR	Number of pairs of (possibly summed) overclock pixels (per output node)
loadTeBlock.outputRegisterMode	1	2	17	ORC_MODE	Output Register Clocking Mode [§B.5]
loadTeBlock.ccdVideoResponse[6]	6	1	18	VIDRESP	Array of CCD video responses, indexed by FEP Id. In cases of conflict, the last entry wins. This selects the video chain response for a given CCD. 0 indicates 1:1, and 1 indicates a 1:4 response.
loadTeBlock.primaryExposure	1	16	19	EXPTIMEA	Primary Exposure Time in 1/10 second units (NOTE: To achieve the minimum integration time, i.e. the smear time, use 0 and only configure a single CCD. To achieve 0.1 second integration time, one must configure only 1 or 2 CCDs, to achieve 0.2 second integration, configure fewer than 5 CCDs. If these constraints are exceeded, the system will improperly allow overlap of parallel transfers on two or more CCDs).
loadTeBlock.secondaryExposure	1	16	20	EXPTIMEB	Secondary Exposure Time in 1/10 second units (NOTE: To achieve the minimum integration time, i.e. the smear time, use 0 and only configure a single CCD. To achieve 0.1 second integration time, configure only 1 or 2 CCDs, to achieve 0.2 second integration, configure fewer than 5 CCDs. If these constraints are exceeded, the system will improperly allow overlap of large parallel transfers on two or more CCDs).
loadTeBlock.dutyCycle	1	16	21	DTYCYCLE	Number of Secondary Exposures per Primary
loadTeBlock.fepEventThreshold[6][4]	6*4	16 ^g	22-27	EVT_THR	Threshold set points for each output node coming into Fep 0
loadTeBlock.fepSplitThreshold[6][4]	6*4	16	28-33	SPL_THR	Split Threshold set points for each output node coming into Fep 0
loadTeBlock.lowerEventAmplitude	1	16	34	PHA_MIN	Minimum accepted event amplitude (pulse height filter)
loadTeBlock.eventAmplitudeRange	1	16	35	PHARANGE	Range of event amplitudes accepted by the pulse height filter. (0xffff: accepts all events that are not below Lower Event Amplitude)
loadTeBlock.gradeSelections[256]	256	1	36	GRADEMAP	This indicates if events whose grade corresponds to the field should be telemetered. 0 indicates don't send, 1 indicates send. [§B.3]
loadTeBlock.histogramCount	1	16	38	HISTOCNT	Number of exposures to accumulate histograms
loadTeBlock.biasCompressionSlotIndex[6]	6	8	39	BCMPSLOT	Slot identifier of Compression table for bias map from each FEP (255 = no compression)
loadTeBlock.rawCompressionSlotIndex	1	8	40	RCMPSLOT	Slot identifier of Compression table for raw mode data from all FEPs (255 = no compression)

Table A–1: Traceability between ACIS IP&CL fields and MSID keywords (Continued)

IP&CL Field Name ^a	Dim ^b	Len ^c	<i>m</i> ^d	Keyword ^e	Description
loadTeBlock.ignoreInitialFrames	1	16	41	EXP_SKIP	The number of whole exposure frames that the FEP is to ignore at the start of a bias calibration. If zero, accept all valid data after the first VSYNC.
loadTeBlock.biasAlgorithmId[6]	6	8	42	BIASALG	Selects bias algorithm to use for indexed FEP [§B.7.1]
loadTeBlock.biasArg0[6]	6	16 ^g	43	BIASARG0	Bias exposure count for indexed FEP [§B.7.1]
loadTeBlock.biasArg1[6]	6	16 ^g	44	BIASARG1	Bias parameter for indexed FEP [§B.7.1]
loadTeBlock.biasArg2[6]	6	16 ^g	45	BIASARG2	Bias parameter for indexed FEP [§B.7.1]
loadTeBlock.biasArg3[6]	6	16 ^g	46	BIASARG3	Bias parameter for indexed FEP [§B.7.1]
loadTeBlock.biasArg4[6]	6	16 ^g	47	BIASARG4	Bias parameter for indexed FEP [§B.7.1]
loadTeBlock.fepVideoOffset[6][4]	6*4	16	48–53	VID_OFF	Video Offset values for each output node coming into FEP 0
loadTeBlock.deaLoadOverride	1	32	54	DEALOAD	If not zero, pointer to explicit DEA Load in RAM
loadTeBlock.fepLoadOverride	1	32	55	FEPLOAD	If not zero, pointer to explicit FEP Load in RAM
scienceReport	MSID=SCI_REPORT_m				Post-science run report sent at the end of a science or bias run
scienceReport.runStartTime	1	32	0	RUNSTART	Science timestamp counter value at start of science run
scienceReport.parameterBlockId	1	32	1	PBLOCK	Parameter Block's Identifier field
scienceReport.windowBlockId	1	32	2	WIND_ID	Window List Parameter Block's Identifier field (0xfffffff if none used)
scienceReport.biasStartTime	1	32	3	BIASTART	Science timestamp counter value at start of bias computation
scienceReport.biasParameterId	1	32	4	BIAS_ID	Parameter Block Identifier from most recent bias computation
scienceReport.exposuresProduced	1	32	5	EXPTOT	Number of exposures produced by the CCDs during the run
scienceReport.exposuresSent	1	32	6	EXPSENT	Number of exposures telemetered by the run
scienceReport.biasErrorCount	1	32	7	BERR_TOT	Total number of pixel bias map errors detected during the run
scienceReport.fepErrorCodes[6]	6	8	8	FEP_ERRS	Array of codes, indexed by FEP_ID, indicating any errors were detected on the corresponding Fep during the run [§B.8]
scienceReport.ccdErrorFlags[6]	6	1	9	CCD_ERRS	Flag indicating if any errors were detected on DEA board used for CCD I/O during the run
scienceReport.deaInterfaceErrorFlag	1	1	10	DEA_ERRS	Flag indicating if any errors were detected on the DEA Interface Board during the run
scienceReport.terminationCode	1	8	11	TERMCODE	Code indicating the reason for the end of the run [§B.11]

- a. Taken from the ACIS IP&CL Structures definitions in Applicable Document 3.
b. This column defines the field dimension within an ACIS telemetry packet.

- c. This column indicates the length in bits of the ACIS telemetry field. All fields represent unsigned integers, except where noted. More significant bytes precede less significant bytes.
- d. This column contains an integer that completes the MSID of the field.
- e. The names in this column are used in Level 0 FITS headers.
- f. When generated in compressed mode, this field will have varying length.
- g. This field is a two's-complement signed integer. All other fields are unsigned.

Appendix B: ACIS Constants

B.1 CCD Identifiers

The following values are used to identify a CCD. These codes are denoted CCD_ID in Table A-1:

Table B-1: CCD_ID Values

Value	Mnemonic	Description
0	CCD_I0	Imaging CCD I0
1	CCD_I1	Imaging CCD I1
2	CCD_I2	Imaging CCD I2
3	CCD_I3	Imaging CCD I3
4	CCD_S0	Spectroscopy CCD S0
5	CCD_S1	Spectroscopy CCD S1
6	CCD_S2	Spectroscopy CCD S2
7	CCD_S3	Spectroscopy CCD S3
8	CCD_S4	Spectroscopy CCD S4
9	CCD_S5	Spectroscopy CCD S5
10	CCD_DESELECT	Code used to indicate no CCD selection

For reference purposes only, the following diagram illustrates the relative layout of the indicated CCDs in the focal plane assembly, as viewed from the High Resolution Mirror Assembly (HRMA). This information was obtained from the Applicable Document 5.

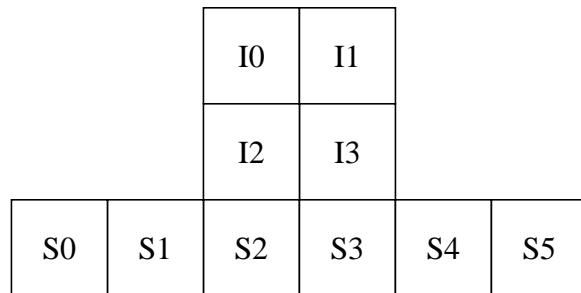

B.2 CCD Row and Column Position Definition

The following illustration defines the CCD Row and Column positions used by the ACIS Software. Row 0 is defined to be the CCD imaging row closest to the Framestore. Column 0 is defined

to be the left-most imaging column (*i.e.* for ABCD readout mode, the first to be clocked out of output node A).

- Indicates relative location of CCD Row 0, Column 0.
- Indicates relative location of CCD Row 1023, Column 0.
- ← Indicates clocking direction of the CCD.

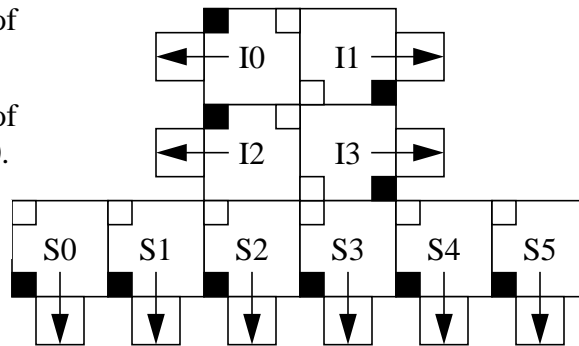

B.3 Event Grade Code Definition

The following illustration defines the CCD Grade Code bit-definitions for a 3x3 event, where the row and column positions are indicated relative to the reported center of the event (the figure is also applicable to 5x5 events, which receive grades based on their inner 9 pixels).

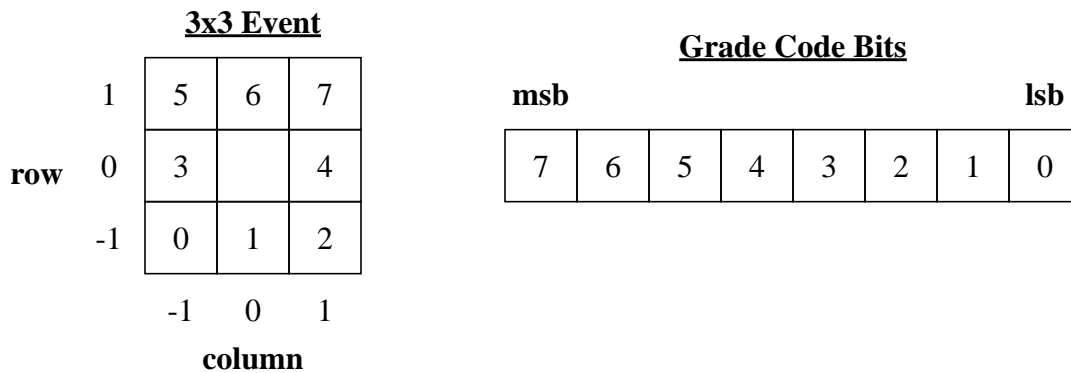

The following illustration defines the CCD Grade Code bit-definitions for a 1x3 event, where the column positions are indicated relative to the reported center of the event.



B.4 FEP Identifiers

The following are used to identify specific Front End Processors. These codes are denoted FEP_ID in Table A-1:

Table B-2: FEP_ID Values

Value	Mnemonic	Description
0	FEP_0	FEP Slot 0 Identifier
1	FEP_1	FEP Slot 1 Identifier
2	FEP_2	FEP Slot 2 Identifier
3	FEP_3	FEP Slot 3 Identifier
4	FEP_4	FEP Slot 4 Identifier
5	FEP_5	FEP Slot 5 Identifier

B.5 Output Register Clocking Modes

The following codes are used to indicate how to clock a CCD's output register. These codes are denoted ORC_MODE in Table A-1:

Table B-3: ORC_MODE Values

Value	Mnemonic	Description
0	QUAD_FULL	Clock charge to all four output nodes
1	QUAD_DIAG	Clock charge away from all four output nodes
2	QUAD_AC	Clock charge toward output nodes A and C
3	QUAD_BD	Clock charge toward output nodes B and D

B.6 DEA Query Identifiers

The following lists the currently defined DEA Controller Housekeeping Query identifiers. They correspond to CCD_ID values of 10 and 11, i.e. the DEA interface control boards. The codes are denoted QUERY_ID in Table A-1:

Table B-4: DEA Controller QUERY_ID Values

Value	Mnemonic	Description
1	DEAHOUSE_CNTL_ADC_TMP_BEP_PCB	DPA Thermistor 1 - BEP PC Board
2	DEAHOUSE_CNTL_ADC_TMP_BEP_OSC	DPA Thermistor 2 - BEP Oscillator
3	DEAHOUSE_CNTL_ADC_TMP_FEP0_MONG	DPA Thermistor 3 - FEP 0 Mongoose
4	DEAHOUSE_CNTL_ADC_TMP_FEP0_PCB	DPA Thermistor 4 - FEP 0 PC Board
5	DEAHOUSE_CNTL_ADC_TMP_FEP0_ACTEL	DPA Thermistor 5 - FEP 0 ACTEL
6	DEAHOUSE_CNTL_ADC_TMP_FEP0_RAM	DPA Thermistor 6 - FEP 0 RAM
7	DEAHOUSE_CNTL_ADC_TMP_FEP0_FB	DPA Thermistor 7 - FEP 0 Frame Buf.
8	DEAHOUSE_CNTL_ADC_TMP_FEP1_MONG	DPA Thermistor 8 - FEP 1 Mongoose
9	DEAHOUSE_CNTL_ADC_TMP_FEP1_PCB	DPA Thermistor 9 - FEP 1 PC Board

Table B-4: DEA Controller QUERY_ID Values (Continued)

Value	Mnemonic	Description
10	DEAHOUSE_CNTL_ADC_TMP_FEP1_ACTEL	DPA Thermistor 10- FEP 1 ACTEL
11	DEAHOUSE_CNTL_ADC_TMP_FEP1_RAM	DPA Thermistor 11- FEP 1 RAM
12	DEAHOUSE_CNTL_ADC_TMP_FEP1_FB	DPA Thermistor 12- FEP 1 Frame Buf.
13	DEAHOUSE_CNTL_ADC_SUBAHK	DEA Video Board ADC
14	DEAHOUSE_CNTL_ADC_SPARE1	Spare - Unused
15	DEAHOUSE_CNTL_ADC_FPTEMP_12	Spare - Focal Plane Temp. Board 12
16	DEAHOUSE_CNTL_ADC_FPTEMP_11	Spare - Focal Plane Temp. Board 11
17	DEAHOUSE_CNTL_ADC_DPAGNDREF1	DPA Ground Reference 1
18	DEAHOUSE_CNTL_ADC_DPA5VHKA	DPA 5V Housekeeping A
19	DEAHOUSE_CNTL_ADC_DPAGNDREF2	DPA Ground Reference 2
20	DEAHOUSE_CNTL_ADC_DPA5VHKB	DPA 5V Housekeeping B
21	DEAHOUSE_CNTL_ADC_UNUSED1	Unused
22	DEAHOUSE_CNTL_ADC_UNUSED2	Unused
23	DEAHOUSE_CNTL_ADC_UNUSED3	Unused
24	DEAHOUSE_CNTL_ADC_UNUSED4	Unused
25	DEAHOUSE_CNTL_ADC_DEA28VDCA	PSMC A DEA 28V DC
26	DEAHOUSE_CNTL_ADC_DEA24VDCA	PSMC A DEA 24V DC
27	DEAHOUSE_CNTL_ADC_DEAM15VDCA	PSMC A DEA -15.5V
28	DEAHOUSE_CNTL_ADC_DEAP15VDCA	PSMC A DEA +15.5V
29	DEAHOUSE_CNTL_ADC_DEAM6VDCA	PSMC A DEA -6V DC
30	DEAHOUSE_CNTL_ADC_DEAP6VDCA	PSMC A DEA +6V DC
31	DEAHOUSE_CNTL_ADC_RAD_PCB_A	Relative Dose Rad. Monitor Side A
32	DEAHOUSE_CNTL_ADC_GND_1	Interface Ground Reference
33	DEAHOUSE_CNTL_ADC_DEA28VDCB	PSMC B DEA 28V DC
34	DEAHOUSE_CNTL_ADC_DEA24VDCB	PSMC B DEA 24V DC
35	DEAHOUSE_CNTL_ADC_DEAM15VDCB	PSMC B DEA -15.5V DC
36	DEAHOUSE_CNTL_ADC_DEAP15VDCB	PSMC B DEA +15.5V DC
37	DEAHOUSE_CNTL_ADC_DEAM6VDCB	PSMC B DEA -6V DC
38	DEAHOUSE_CNTL_ADC_DEAP6VDCB	PSMC B DEA +6V DC
39	DEAHOUSE_CNTL_ADC_RAD_PCB_B	Relative Dose Rad. Monitor Side B
40	DEAHOUSE_CNTL_ADC_GND_2	Ground

The following lists the currently defined DEA Analog Housekeeping Query identifiers. They correspond to CCD_ID values of 0–9, i.e. the DEA analog boards. These identifiers are based on Applicable Document 4. Queries which fail, either due to a time-out or because the queried board

is not powered, will be indicated in the telemetered housekeeping packet as having a value of 0xffff in the queried data. The codes are denoted QUERY_ID in Table A-1:

Table B-5: DEA Analog QUERY_ID Values

Value	Mnemonic	Description
1	DEAHOUSE_CCD_REG_0	Register 0 Sequencer Control
2	DEAHOUSE_CCD_REG_1	Register 1 Video ADC Control
3	DEAHOUSE_CCD_REG_2	Register 2
4	DEAHOUSE_CCD_REG_3	Register 3
128	DEAHOUSE_CCD_PIA_P	Image Array Parallel +
129	DEAHOUSE_CCD_PIA_M	Image Array Parallel -
130	DEAHOUSE_CCD_PFS_P	Framestore Parallel +
131	DEAHOUSE_CCD_PFS_M	Framestore Parallel -
132	DEAHOUSE_CCD_S_P	Serial Register +
133	DEAHOUSE_CCD_S_M	Serial Register -
134	DEAHOUSE_CCD_R_P	Reset Gate +
135	DEAHOUSE_CCD_R_M	Reset Gate -
136	DEAHOUSE_CCD_OG	Output Gate Bias Level
137	DEAHOUSE_CCD_SCP	Scupper
138	DEAHOUSE_CCD_RD	Reset Diode
139	DEAHOUSE_CCD_DR0	Drain Output Channel A
140	DEAHOUSE_CCD_DR1	Drain Output Channel B
141	DEAHOUSE_CCD_DR2	Drain Output Channel C
142	DEAHOUSE_CCD_DR3	Drain Output Channel D
143	DEAHOUSE_CCD_SPARE	Spare Housekeeping Channel
144	DEAHOUSE_CCD_TEMP_BOARD	Board Temperature (RTD4)
145	DEAHOUSE_CCD_TEMP_SRAM	SRAM Temperature (RTD3)
146	DEAHOUSE_CCD_TEMP_ADC	ADC Temperature (RTD2)
147	DEAHOUSE_CCD_TEMP_ACTEL	Gate Array Temperature (RTD1)

B.7 Bias Algorithm Selection Codes

The following define the Bias Algorithm selection codes for Timed Exposure Mode and Continuous Clocking Mode. The determination of which algorithm is used and which parameters affect the computation is derived from the parameter values.

B.7.1 Timed Exposure Mode

Table B-6: BIASALG Values

Value	Mnemonic	Description
0	FEP_NO_BIAS	None
1	FEP_BIAS_1	Algorithm #1: Whole Frame Mode

Table B–6: BIASALG Values

Value	Mnemonic	Description
2	FEP_BIAS_2	Algorithm #2:Strip Mode

The following table (copied from the “FEP Timed Exposure Bias Calibration” section of Applicable Document 2) indicates how the parameters from the Timed Exposure Parameter Block (see “Load TE Block” in Applicable Document 3) affect the bias computation for each mode.

Table B–7: Timed Exposure Bias Parameter Usage

Field	“Whole-Frame” Mode	“Strip” Mode
BIASALG	FEP_BIAS_1	FEP_BIAS_2
BIASARG0	Number of conditioning exposures (PHASE2)	Number of exposures per pixel
BIASARG1	Number of approximation-to-mean exposures (PHASE3), including the conditioning exposures listed in BIASARG0.	=0 to use the <i>mean</i> algorithm =1 to use the <i>fractile</i> algorithm =2 to use the <i>medmean</i> algorithm
BIASARG2	Rejection threshold for low-pixel elimination (immediately prior to PHASE3)	For <i>mean</i> and <i>medmean</i> , specifies σ rejection criterion. For <i>fractile</i> , index of sorted pixel array.
BIASARG3	Threshold for event rejection (PHASE3)	Specifies how many of the largest samples are to be removed from the pixel array before applying the <i>mean</i> , <i>medmean</i> , or <i>fractile</i> algorithm.
BIASARG4	Rejection threshold for approximation-to-mean	Specifies how many of the smallest samples are to be removed from the pixel array before applying the <i>mean</i> , <i>medmean</i> , or <i>fractile</i> algorithm.

B.7.2 Continuous Clocking Mode

The following table (copied and adjusted from the “FEP Continuous Clocking Bias Calibration” section of Applicable Document 2) indicates how the parameters from the Continuous Clocking Parameter Block (see “Load Cc Block” in Applicable Document 3) affect the bias computation.

Table B–8: Continuous Clocking Bias Parameter Usage

Field	Description
BIASALG	=0 to use the iterated <i>mean</i> algorithm; =1 to use the <i>fractile</i> algorithm
BIASREJ	For <i>mean</i> , specifies σ rejection criterion. For <i>fractile</i> , index of sorted pixel array.

B.8 FEP Science Report Error Codes

The following list the FEP error codes supplied by the Science Run report. The first set of codes are defined by the FEP/BEP interface, and are supplied by the FEP in response to a command or action initiated by the BEP. The second set are defined by the BEP to report power, reset condi-

tions, or I/O error conditions when attempting to access a FEP. These codes are denoted FEP_ERRS in Table A-1:

Table B-9: FEP_ERRS Values

Value	Mnemonic	Description
0	FEP_CMD_NOERR	no errors detected
1	FEP_CMD_ERR_NO_RUN	no command currently running
2	FEP_CMD_ERR_UNK_CMD	unknown command type
3	FEP_CMD_ERR_PARM_LEN	parameter block too long
4	FEP_CMD_ERR_PARM_TYPE	unknown parameter block type
5	FEP_CMD_ERR_QUAD_CODE	unknown quadrant code
6	FEP_CMD_ERR_BIAS_TYPE	unknown bias type code
7	FEP_CMD_ERR_BIAS_PARM0	bad bias parm 0
8	FEP_CMD_ERR_NROWS	bad number of rows
9	FEP_CMD_ERR_NCOLS	bad number of columns
10	FEP_CMD_ERR_NOCLK	bad number of overlocks
11	FEP_CMD_ERR_NHIST	bad histogram exposure count
12	FEP_CMD_ERR_NO_PARM	no parameter block loaded
13	FEP_CMD_ERR_BAD_CMD	illegal secondary command
14	FEP_CMD_ERR_NO_BIAS	no bias map stored
128	FEP_ERR_LOCK_TIMEOUT	Timeout on FEP lock
129	FEP_ERR_NO_POWER	FEP has no power
130	FEP_ERR_IS_RESET	FEP is reset
131	FEP_ERR_NO_CMDRING	FEP program has no command mailbox
132	FEP_ERR_REPLY_TIMEOUT	FEP reply timed-out
133	FEP_ERR_BAD_REPLY_TYPE	FEP produced bad reply
134	FEP_ERR_BAD_MBOX_STATE	FEP mailbox state invalid

B.9 FEP Science Mode Codes

B.9.1 Timed Exposure Mode

The following define the FEP mode codes for Timed Exposure Mode. These codes are denoted FEP_MODE in Table A-1:

Table B-10: Timed-Exposure FEP_MODE Values

Value	Mnemonic	Description
0	FEP_TE_MODE_RAW	Raw Mode
1	FEP_TE_MODE_HIST	Histogram Mode
2	FEP_TE_MODE_EV3x3	3x3 Event Detection Mode
3	FEP_TE_MODE_EV5x5	5x5 Event Detection Mode

B.9.2 Continuous Clocking Mode

The following define the FEP mode codes for Continuous Clocking Mode. These codes are denoted FEP_MODE in Table A-1:

Table B-11: Continuous Clocking FEP_MODE Values

Value	Mnemonic	Description
0	FEP_CC_MODE_RAW	Raw Mode
1	FEP_CC_MODE_EV1x3	1x3 Event Detection Mode

B.10 BEP Packing Mode Codes

B.10.1 Timed Exposure

The following define the BEP Event List Packing Codes for Timed Exposure Mode. These codes are denoted BEP_MODE in Table A-1:

Table B-12: Timed Exposure BEP_MODE Values

Value	Mnemonic	Description
0	BEP_TE_MODE_FAINT	3x3 or 5x5 Faint Mode Event Telemetry
1	BEP_TE_MODE_FAINTBIAS	3x3 Faint with Bias Event Telemetry
2	BEP_TE_MODE_GRADED	3x3 Graded Event Telemetry

B.10.2 Continuous Clocking

The following define the BEP Event List Packing Codes for Continuous Clocking Mode. These codes are denoted BEP_MODE in Table A-1:

Table B-13: Continuous Clocking BEP_MODE Values

Value	Mnemonic	Description
0	BEP_CC_MODE_FAINT	1x3 Faint Mode Event Telemetry
1	BEP_CC_MODE_GRADED	1x3 Graded Event Telemetry

B.11 Science Mode Termination Codes

The following list the science mode termination reason codes. These codes are denoted TERM-CODE in Table A-1:

Table B-14: TERMCODE Values

Value	Mnemonic	Description
0	SMTERM_UNUSED	Unused
1	SMTERM_STOPCMD	Commanded to Stop i.e. normal term.
2	SMTERM_BIASDONE	Bias-only Run completed
3	SMTERM_RADMON	Radiation Monitor was asserted
4	SMTERM_CLOBBBERED	Clobbered by another start command
5	SMTERM_FEP_BIAS_START	FEP Bias Processing did not start
6	SMTERM_FEP_DATA_START	FEP Data Processing did not start
7	SMTERM_CCD_BIAS_START	Cmd. start clock. CCDs for bias failed
8	SMTERM_CCD_DATA_START	Cmd. start clock. CCDs for data failed
9	SMTERM_CCD_BIAS_STOP	Cmd. stop clock. CCDs for bias failed
10	SMTERM_PROC_PARM_INVALID	Processing Parameter out of range
11	SMTERM_DEA_PARM_INVALID	DEA Parameter out of range
12	SMTERM_FEP_PARM_INVALID	FEP Parameter out of range
13	SMTERM_FEP_CONFIG_ERROR	FEP Configuration Error

Table B–14: TERMCODE Values (Continued)

Value	Mnemonic	Description
14	SMTERM_DEA_IO_ERROR	I/O errors, or no CCD controllers on
15	SMTERM_FEP_IO_ERROR	I/O errors, or no FEPs are on
16	SMTERM_UNSPECIFIED	Reason is unspecified

B.12 Miscellaneous FEP Constants

The following list some miscellaneous constants and limits used by the Front End Processor software. The mnemonics are those used by the ACIS flight software.

Table B–15: Miscellaneous FEP Constants

Mnemonic	Value	Description
BIAS_BAD	0xffe	bias parity error value
PIXEL_BAD	0xffff	pixel in bad pixel map
MAX_NOCLK	30	maximum overlocks per output node
MAX_NOCLKR	16	max raw overlocks per output node
MAX_NROWS	1024	maximum number of pixel rows
MAX_NCOLS	1024	maximum number of pixel columns
MAX_STRIP	64	maximum bparm[0] in strip mode
CCLK_NROWS	512	number of pixel rows in CClk mode
PIXEL_MASK	0xffff	valid pixel and bias bits
INITSKIP	2	number of science exposures to skip

B.13 Miscellaneous BEP Constants

The following list some miscellaneous constants and limits used by the Back End Processor software. The mnemonics are those used by the ACIS flight software.

Table B–16: Miscellaneous BEP Constants

Mnemonic	Value	Description
CORNER_MEAN_LOW	-4096	Graded Mode Corner Mean below -4095
CORNER_MEAN_MISSING	4095	Graded Mode—No Valid Corner Pixels